

PHILIPS

A/321
Tel 5444

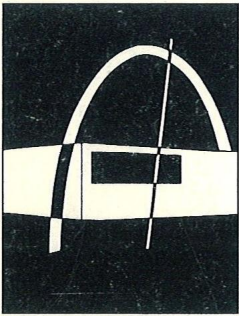

Digital multimeter

PM2422A

9447 024 221..

9499 470 08802

740901/A5/A6



PHILIPS



Manual

Digital multimeter **PM 2422A**

9447 024 221..



IMPORTANT

In correspondence concerning this instrument please quote the type number and the serial number as given on the type plate at the rear of the instrument.

WICHTIG

Bei einem Schriftverkehr über dieses Gerät bitte immer die Typennummer und die Seriennummer angeben, die auf dem Typenschild an der Rückseite des Gerätes stehen.

ATTENTION

Veuillez indiquer le numéro de type et le numéro de série tels que portés sur la plaque du constructeur à l'arrière de l'instrument, dans toute correspondance relative à cet appareil.

CONTENTS

GENERAL / ALLGEMEINES / GENERALITES

I.	INTRODUCTION	6
	EINLEITUNG	20
	INTRODUCTION	34
II.	TECHNICAL DATA	6
	TECHNISCHE DATEN	20
	CARACTERISTIQUES TECHNIQUES	34
III.	ACCESSORIES	11
	ZUBEHOER	25
	ACCESSOIRES	39
IV.	PRINCIPLE OF OPERATION	13
	WIRKUNGSWEISE	27
	PRINCIPE DE FONCTIONNEMENT	41

DIRECTIONS FOR USE / GEBRAUCHSANWEISUNG / MODE D'EMPLOI

V.	INSTALLATION	16
	INSTALLATION	30
	MISE EN PLACE	48
VI.	OPERATION	16
	BEDIENUNG	30
	MISE EN OEUVRE	48

SERVICE DATA

VII.	CIRCUIT DESCRIPTION	57
VIII.	ACCESS	70
IX.	MAINTENANCE AND SERVICE	71
X.	CHECKING AND ADJUSTING SURVEY	84
XI.	CHECKING AND ADJUSTING	86
XII.	PARTS LIST	94

FIGURES

ABBILDUNGEN

FIGURES

1. EHT probe PM 9246	12
Hochspannungs-Messkopf PM 9246	26
Sonde THT PM 9246	40
2. UHF probe PM 9200	42
UHF Messkopf PM 9200	42
Sonde UHF PM 9200	42
3. UHF T-connector PM 9250	42
UHF-T-Stück PM 9250	42
Té connecteur UHF PM 9250	42
4. Current Transformer PM 9245	42
Stromwandler PM 9245	42
Transformateur de courant PM 9245	42
5. Shunt PM 9244	42
Shunt PM 9244	42
Shunt PM 9244	42
6. Measuring clip PM 9261	42
Messclip PM 9261	42
Dispositif de connexion PM 9261	42
7. Basic circuit of the ADC	46
Prinzipschaltbild des Analog-Digital-Umsetzers	46
Circuit de base du convertisseur analogique-numérique	46
8. Block diagram	46
Blockschaltbild	46
Schéma fonctionnel	46
9. Adaptation of the mains transformer	50
Anpassung Netztransformateur	50
Adaptation du transformateur secteur	50
10. Front view	54
Vorderansicht	54
Vue de l'avant	54
11. Rear View	54
Rückansicht	54
Vue de l'arrière.	54
12. Direct and alternating voltage measuring circuit	58
Messschaltung für Gleich- und Wechselspannung	58
Circuit de mesure de courant alternatif et continu	58
13. Direct and alternating measuring circuit	58
Messschaltung für Gleich- und Wechselstrom	58
Circuit de mesure de courant alternatif et continu	58

14. Principle of resistance measurement	61
15. Resistance measuring circuit	61
16. 1x/ 10x Amplifier	63
17. AC-to-DC converter	63
18. $+V_{REF}$ and $-V_{REF}$	63
19. Analog-to-digital converter	65
20. Clock oscillator	65
21. 4 Decade counter	67
22. Anode switches	67
23. Sequence diagram	68
24. Overrange detector	68
25. Location of test points at component side of the printed wiring board	74
26. Location of test points at conductor side of the printed wiring board	78
27. Location of jumpers on the printed wiring board	83
28. Clock pulse	86
29. Location of adjusting elements	92
30. Front view with indication of item numbers	95
31. Rear view with indication of item numbers	95
32. Top view	101
33. Bottom view	101
34. Printed wiring board U1	102
35. Circuit diagram supply section PM 2422 A	103
36. Circuit diagram analog and digital section PM 2422 A	107

I. INTRODUCTION

The Philips digital multimeter PM 2422 A is an accurate 3+1 digit instrument with a maximum reading of 1999 to measure:

- DC and AC voltages of 100 μ V ... 1000 V (600 V AC,) 5 ranges
- DC and AC currents of 100 nA ... 2 A, 5 ranges
- Resistances of 0.1 Ω ... 20 M Ω , 6 ranges
- DC high voltages up to 30 kV with the EHT probe PM 9246
- UHF voltages with UHF probe PM 9200 up to 800 MHz.

For frequencies above 30 MHz it is advisable to use T-connector PM 9250 in conjunction with this probe.

- DC and AC currents up to 31.6 A with shunt PM 9244
- AC currents up to 100 A with current transformer PM 9245

Operation of the instrument is easy.

Selection of the measuring ranges is effected by a rotary switch, and AC and DC selection by push-buttons.

The decimal point is set automatically by switching the ranges.

The polarity of direct voltages and currents is indicated automatically.

Only the -sign is displayed.

The instrument is protected against overloads on all ranges up to at least 250 V.

This efficiently designed instrument can be employed for all applications in modern electronics.

II. TECHNICAL DATA

Properties expressed in numerical values with tolerances are guaranteed by the manufacturer. Numerical values without tolerances are given for general information and represent the properties of an average instrument.

The data below are applicable at 23°C \pm 1°C unless otherwise stated.

A. MEASURING RANGES

1. Direct voltages

Measuring range

0.1 mV ... 1000 V

5 ranges up to 200 mV, 2 V, 20 V, 200 V and 1 kV

Resolution	100 μ V
Accuracy	$\pm 0.1\%$ of range and $\pm 0.1\%$ of reading
Temperature coefficient	± 1 digit / 5°C
Input resistance	10 $\text{M}\Omega \pm 0.2\%$
Input capacity	< 100 pF
Series mode rejection	> 66 dB at 50 Hz and 60 Hz
Common mode rejection	> 120 dB at DC, 50 Hz and 60 Hz
2. <u>Alternating voltages</u>	
Measuring range	0.1 mV ... 600 V 5 ranges up to 200 mV, 2 V, 20 V, 200 V and 600 V
Maximum resolution	100 μ V
Input impedance	10 $\text{M}\Omega \pm 0.2\%$ // max. 100 pF
Accuracy	$\pm 0.2\%$ of range and $\pm 0.2\%$ of reading } at a frequency of 1 kHz $\pm 0.3\%$ of range and $\pm 0.3\%$ of reading } at a frequency of 30 Hz ... 20 kHz $\pm 0.5\%$ of range and $\pm 0.5\%$ of reading } at a frequency of 20 kHz ... 25 kHz
Temperature coefficient	± 1 digit / 5°C
Frequency range	30 Hz ... 25 kHz
Max. input voltage	600 V
Max. frequency on 600 V range	1 kHz
3. <u>Direct currents</u>	
Measuring range	100 nA ... 2 A 5 ranges up to 200 μ A, 2 mA, 20 mA, 200 mA and 2 A
Maximum resolution	100 nA
Accuracy	$\pm 0.3\%$ of range and $\pm 0.3\%$ of reading
Temperature coefficient	± 1 digit / 4°C
Voltage loss	< 250 mV for currents ≤ 200 mA < 600 mV for 2 A

4. Alternating currents

Measuring range	100 nA ... 2 A 5 ranges up to 200 μ A, 2 mA, 20 mA, 200 mA and 2 A
Maximum resolution	100 nA
Accuracy	$\pm 0.4\%$ of range and $\pm 0.4\%$ of reading
Frequency range	30 Hz ... 1 kHz
Temperature coefficient	± 1 digit / 4°C
Voltage loss	< 250 mV for current ≤ 200 mA < 600 mV for 2 A

5. Resistances

Measuring range	0.1 Ω ... 20 M Ω 6 ranges up to 200 Ω , 2 k Ω , 200 k Ω , 2 M Ω and 20 M Ω
Maximum resolution	0.1 Ω
Accuracy	$\pm 0.2\%$ of range and $\pm 0.2\%$ of reading } for ranges < 200 k Ω $\pm 0.2\%$ of range and $\pm 0.5\%$ of reading } for the 2 M Ω and 20 M Ω ranges
Temperature coefficient	± 1 digit / 3°C for ranges ≤ 200 k Ω ± 1 digit / 2°C for the 2 M Ω and 20 M Ω ranges
Measuring current	1 mA for the 200 Ω and 2 k Ω ranges 10 μ A for the 20 k Ω and 200 k Ω ranges 100 nA for the 2 M Ω and 20 M Ω ranges
Max. voltage with open input	< 2.7 V for the 200 Ω , 20 k Ω , and 2 M Ω ranges < 12 V for the 2 k Ω , 200 k Ω and 20 M Ω ranges
Semi-conductors	Can be tested forwards on the 2 k Ω range and reverse on the 2 M Ω and 20 M Ω ranges

B. GENERAL DATA

1. Display

Number of digits	3 + 1
Max. display	1999
Polarity	Automatic display of "-" sign No indication for + DC, AC and Ohm
Overrange	The digit of the hundreds displays 0, the others are blanked.
Decimal point	Set automatically by range selector

2. Analog to digital conversion

Conversion system	Delta pulse modulation system [⌘]
Sampling rate	2 times per second, memory keeps the reading displayed during the measuring time
Display control	Serial, Scan frequency 512 Hz

3. Input

Measuring input	Floating
Range selection	Manual
Max. common mode signal	500 V d.c. 350 V a.c., 50 Hz
Capacity "0" - \perp	1.8 nF
Maximum voltage between V-R and \perp	1000 V d.c. or 1000 V r.m.s.

4. Temperature range

Ambient temperature	0 ... 45°C
Zero point drift	± 1 digit / 4°C

5. Protection

Max. permissible voltages	Range	Value
	Ranges ≤ 2 V DC } and AC	350 V d.c.; 300 V a.c. (50 Hz)
	Ranges > 2 V AC	500 V d.c.; 600 V a.c.
	Ranges > 2 V DC	1.2 kV d.c.; 600 V a.c.
	The voltage ranges are protected for overloads up to 3 kV supplied by high ohmic sources	
Current ranges	6 A fuse and power diodes for protection of the shunts. Max. permissible voltage 250 V d.c. or a.c.	

⌘ Philips patent

Resistance ranges

Protected against 250 V d.c. or a.c. (50 Hz)
For ranges $\leq 2 \text{ k}\Omega$ above 30 V a fuse (125 mA)
will blow

6. Power supply

Mains voltage

110 V or 220 V $\pm 15\%$
Additional adaption by 18 V is possible

Frequency

40 - 60 Hz

Power consumption

30 VA

C. MECHANICAL DATA

Dimensions

Height: 145 mm
Width : 236 mm
Depth : 298 mm

Weight

about 3.5 kg

III. ACCESSORIES

A. SUPPLIED AS PART OF THE EQUIPMENT

Set of measuring leads with test pins PM 9260
Interconnection strip between terminals "0" and 

B. OPTIONALLY AVAILABLE

EHT probe PM 9246 (fig. 1, page 12)

The HT probe PM 9246 is suitable for measuring direct voltages up to 30 kV.

The PM 9246 may be used for measuring instruments with an input impedance of 100 M Ω , 10 M Ω or 1.2 M Ω (selectable).

TECHNICAL DATA

Maximum voltage	30 kV
Attenuation	1000 x
Input impedance	600 M Ω \pm 5%
Accuracy	\pm 3% for instruments input impedance of 10 M Ω and 100 M Ω \pm 5% for instruments input impedance of 1.2 M Ω

Note:

Pay attention to safe earth connections

UHF probe 9200 (fig. 2, page 42)

The UHF probe PM 9200 is suitable for measuring alternating voltages between 10 mV and 16 V.

Frequency range	100 kHz ... 800 MHz
Frequency response	100 kHz ... 1 MHz \pm 10% 1 MHz .. 300 MHz \pm 5% 300 MHz .. 800 MHz \pm 10%
Input impedance	1 MHz .. 110 k Ω 10 MHz .. 80 k Ω 50 MHz .. 25 k Ω
Input capacitance	2 pF
Max. permissible voltage on the probe	450 V d.c.

At frequencies above 30 MHz these tolerances apply only if T-connector PM 9250 is used.

UHF T-connector PM 9250 (fig. 3, page 42)

Impedance	50 Ω
Frequency response	0.1 ... 1000 MHz
Standing wave ratio	0.1 ... 800 MHz : 1.1 800 ... 1000 MHz : 1.2

Current transformer PM 9245 (fig. 4, page 42)

With this transformer it is possible to measure alternating currents over 10 A up to 100 A.

Transfer factor	1000 × (100 A = 100 mA)
Transfer error	± 3%
Frequency range	45 Hz ... 1 kHz
Secondary voltage loss	< 200 mV
Max. voltage with respect to earth	400 V a.c.
Max. air-gap	0.05 mm

Before measuring connect the current transformer to the instrument.

Prevent pollution of the core-parts.

Shunt PM 9244 (fig. 5, page 42)

With this shunt it is possible to measure d.c. and a.c. (max. 1 kHz) currents up to 31.6 A.

Current range	10 A and 31.6 A
Output voltage	100 mV and 31.6 mV
Accuracy	100 mV: ± 1% 31.6 mV : ± 2%
Dissipation	max. 3.16 W
Dimensions	Height : 55 mm Width : 140 mm Depth : 65 mm

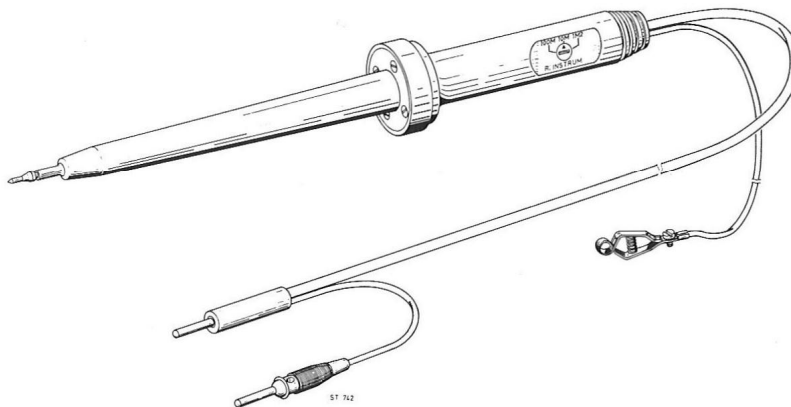

Fig. 1.

IV. PRINCIPLE OF OPERATION (Fig. 8)

A. INPUT CIRCUIT

The purpose of the input circuit is to supply a direct voltage of 2 V to the ADC input, at end of range values.

The analog sections translates all input signals viz. d.c. and a.c. voltages, d.c. and a.c. currents and resistances to this signal of 2 V.

For the d.c. and a.c. voltages the same divider is used.

The attenuated signal is supplied to an 1 x or 10 x amplifier with an output of 2 V d.c. or 2 V_{r.m.s.}

In the case of a.c. measurements the output signal of the amplifier is supplied to an AC/DC converter, which is out of circuit in the case of d.c. measurements.

Currents supplied to input I are converted into voltages by shunts.

These voltages are also supplied to the 1 x or 10 x amplifier and then directly, or in the case of a.c. currents via the AD/DC converter, supplied to the ADC.

For resistance measurements, a constant current is passed through the unknown resistance.

The following currents are used in the different ranges:

Ranges	Current	Measuring voltage (at end of range)
200 Ω	1 mA	200 mV
2 k Ω	1 mA	2 V
20 k Ω	10 μ A	200 mV
200 k Ω	10 μ A	2 V
2 M Ω	100 nA	200 mV
20 M Ω	100 nA	2 V

The measuring voltage across the unknown resistance is supplied to the ADC via the 1 x or 10 x amplifier.

B. DIGITAL SECTION

The analog to digital converter of the PM 2422 A is based on the delta-pulse modulation principle. This integrating system ensure good linearity and series mode rejection. Furthermore the circuit contains a minimum of critical elements, only the accuracy of the reference voltage is important for the accuracy of the ADC.

The basic circuit of the ADC is shown in Fig. 7. The operation is as follows:

With a comparator the input voltage V_x is compared with voltage V_c

The output of the comparator controls switch S via flip-flop in such a way that the positive reference voltage ($+V_{REF}$) is connected to R1 if $V_c < V_x$ or the negative reference ($-V_{REF}$) if $V_c > V_x$.

Suppose V_x is positive with respect to V_c and switch S to position $+V_{REF}$.

This results in charging the capacitor so that V increases until it becomes larger than V_x .

At the first clock pulse after V_c has become larger than V_x , flip-flop is set; switch S is set to position $-V_{REF}$. Capacitor $C1$ will be discharged until V_c becomes smaller than V_x . Then switch S is set again to the starting position (S in position $+V_{REF}$) at the next clock pulse.

Due to this compensation method the average value of V_c will be equal to V_x . If V_x has a constant value (a.d.c. level) the average charge of capacitor $C1$ must be also constant. This means, that the charge supplied (Q_c) is equal to the charge drained off (Q_d) when integrated over a longer period (measuring time t_m).

$$\text{Charge supplied: } Q_c = \frac{+V_{REF} - V_c}{R} \cdot t_c$$

$$\text{Charge drained: } Q_d = \frac{V_c - (-V_{REF})}{R} \cdot t_d$$

$$\text{thus: } V_c = V_x = \frac{t_c - t_d}{t_c + t_d} \cdot V_{REF} \text{ or } V_x = \left(\frac{t_c}{t_c + t_d} - \frac{t_d}{t_c + t_d} \right) V_{REF}.$$

in which t_c = sum of the charging times, t_d = sum of the draining times during time t_m ($+V_{REF}$ and $-V_{REF}$ have the same absolute value).

By counting the number of clock pulses during the charging time (t_c) and subtracting the clock pulses during the draining time (t_d) this results in a number of clock pulses which corresponds to the input voltage.

Assume: N = total number of clock pulses during t_m

T = period time of clock pulse

then t_m = measuring time = $NT = t_c + t_d$

If during t_c , n clock pulses are used, then during t_d $N-n$ pulses are used, so that V_x becomes

$$V_x = \frac{nT - (NT - nT)}{NT} V_{REF} = \frac{2n - N}{N} V_{REF}.$$

If $2n - N = n'$ = the number of pulses to be counted, then:

$$n' = V_x \frac{N}{V_{REF}}$$

N is a fixed number of pulses determined by a timer and amounts to 2046. When using a reference voltage of 2.046 V the formula becomes

$$n' = 1000 V_x \quad (V_x \text{ in volts})$$

(In PM 2422 A capacitor C1 is connected between the inputs of the comparator to obtain a better series mode rejection).

The counting of pulses is realised in an up-down counter which is included in a MOS integrated circuit. This circuit contains, moreover:

- An input flip-flop (FF, described before)
- Two analog switches (S) to switch the positive and negative reference voltage
- A polarity detector
- A timer to control the measuring time
- A clock oscillator
- A pulse output circuit which controls the 4-decade counter.

The latter circuit counts the pulses supplied by the ADC.

The number of counted pulses will be transferred to a memory after which the counter will be reset to zero by a reset pulse from the ADC.

A new measuring cycle can start now.

A multiplexer connects alternately each decade of the memory to the decoder-driver, simultaneously a pulse arises to drive the anode switch of the corresponding indicator tube.

Via the decoder-driver the decoded number will be transferred to one of the 4 indicator tubes, the cathodes of which are switched in parallel.

Only that indicator, the anode switch of which is closed, will light up.

As the switching speed is 512 times per second it seems that all indicators light at the same time.

DIRECTIONS FOR USE

V. INSTALLATION

A. MAINS SUPPLY

Before the instrument is connected to the mains, check that the instrument is set to the local voltage.

If necessary, connect the transformer windings as shown in Fig. 9.

The instrument is set to 220 V in the factory.

B. FUSE

Make sure that only fuses with the required current rating and of the specified type are used. The use of repaired fuses and the short-circuiting of fuse holders is prohibited.

The rating of the mains fuse mounted inside on the rear plate (fig. 32, page 101) should be:

- for 110 V : 250 mA, delayed action
- for 220 V : 140 mA, delayed action

C. EARTHING

The instrument should be connected to a protective earth in accordance with the local safety regulation. This can be effected via the 3-core means lead. The mains plug should only be inserted in a socket outlet provided with a protective earth contact, the protective action of which is not cancelled by the use of an extension card or device without protective conductor.

VI. OPERATION

A. SWITCHING ON (fig. 10)

The instrument is ready for use after connection to the mains and earthing. It is switched on by means of mains switch POWER ON (SK3)

Then the display tubes light up.

A warming-up time of approximately 30 min. should be observed to obtain full accuracy.

B. ELECTRICAL ZERO SETTING

- Switch on the instrument and allow to warm up for approximately 30 min.
- Interconnect terminals "0" (BU2) and "V-R" (BU3)
- Press push-button DC (SK2/1)
- Set range selector (SK1) to position 200 mV
- Adjust the reading to 00.0 by means of potentiometer "ZERO" (screwdriver adjustment at the rear of the instrument).
- If the indicator "-" blinks it is an indication that the zero setting has been effected correctly.

C. CALIBRATION

Calibration of this instrument may only be carried out if a DC standard with an accuracy of at least $\pm 0.04\%$ (preferably $\pm 0.02\%$) is available.

For calibration reference is made to chapter XI sub-point D.1.

D. MEASURING

1. Direct and alternating voltages

- Select measuring mode DC-R or AC
- Select the correct measuring range with range selector SK1
- Connect the test voltage to terminals "0" (BU2) and V-R (BU3)

Notes:

- For floating measurements, remove interconnection strip between "0" (BU2) and \perp (BU1).
- The capacitance between terminals "0" and \perp is approximately 1.8 nF.
- For d.c. voltages the polarity indicator indicates the polarity on terminal V-R with respect to terminal "0". Only the "-" sign will be displayed.
- Maximum permissible voltage between terminal "0" and chassis \perp is 500 V d.c. or 350 V a.c. 50 Hz
- Maximum permissible voltage between terminal V-R and chassis \perp is 1000 V d.c. or 1000 V r.m.s.
- Maximum permissible voltage:

Range	Measuring mode DC	Measuring mode AC
200 mV } 2 V }	350 V d.c.; 300 V a.c. (50 Hz)	350 V d.c.; 300 V a.c. (50 Hz)
20 V } 200 V } 1000 V }	1.2 kV d.c.; 600 V a.c. (50 Hz)	500 V d.c.; 600 V a.c. (50 Hz)

2. EHT voltages up to 30 kV with probe PM 9246

- Select measuring mode DC-R
- Connect the probe terminals "0" and V-R (terminals "0" and \perp should be interconnected by the interconnection strip)
- Connect the earthing clip of the probe to a proper earth
- Select the 10 M Ω range on the probe
- With the range selector the following ranges are possible.

Range selector to position	HT range
20 V	2 kV max.
200 V	20 kV max.
1000 V	30 kV max. (see note)

Notes:

- Maximum permissible d.c. voltage 30 kV (range end is 100 kV)
- The position of the decimal point should be observed.

3. UHF voltages (with probe PM 9200 and T-connector PM 9250)

- Select measuring mode DC-R
- Connect the probe to terminals "0" and V-R, with the earthing pin to "0" (terminals "0" and \perp should be interconnected)
- Set measuring range selector to the desired position.

Notes:

- The maximum permissible voltage on the probe is 16 V_{r.m.s.}
- The correction factor on the calibration curve of the probe should be taken into account.

4. Direct and alternating currents

- Select measuring mode DC-R or AC
- Select the correct measuring range with selector SK1
- Connect the current source to be measured to terminals "0" and I (BU4)

Notes:

- The polarity indicator shows the polarity at terminal I with respect to terminal "0". Only the "-" sign will be displayed.
- Maximum permissible voltage on the current terminals in all ranges 250 V a.c. or d.c.
- The shunts are protected with a 6 A fuse (see chapter VIII sub-point B).

5. DC and AC (max. 1 kHz) currents up to 31.6 A with DC shunt PM 9244

- Select measuring mode DC-R or AC
- Connect the output sockets + and - of shunt PM 9244 to terminals V-R and "0" (BU3 and BU2)
- Set the range selector to position 200 mV
- Connect the current source to terminals - and 10 A or 31.6 A dependent on the current to be measured.
- By means of switch SK1 (Fig. 5) the output voltage of shunt PM 9244 can be switched-over from 100 mV to 31.6 mV.

6. AC currents up to 100 A with current transformer PM 9245

- Select measuring mode AC
- Connect the terminals of transformer PM 9245 to terminals "0" and I
- Set the range selector to position 200 mA
- Pass the current-carrying conductor through the opening of the transformer.
- Maximum permissible alternating current 100 A.
- Frequency range 45 Hz - 1 kHz.

7. Resistors

- Select measuring mode DC-R
- Connect the unknown resistor to terminals "0" and V-R
- Select the correct measuring range.

Notes:

- The measuring current is : 1 mA for the 200 Ω and 2 k Ω ranges,
 10 μ A for the 20 k Ω and 200 k Ω ranges and
 100 nA for the 2 M Ω and 20 M Ω ranges.
- For measuring resistors measuring clip PM 9261 can be used.
- Semi-conductors can be measured in forward direction of range 2 k Ω . The display shows the diode voltage in forward direction of 1 mA. Terminal "V-R" (BU3) is positive with respect to terminal "0" (BU2).

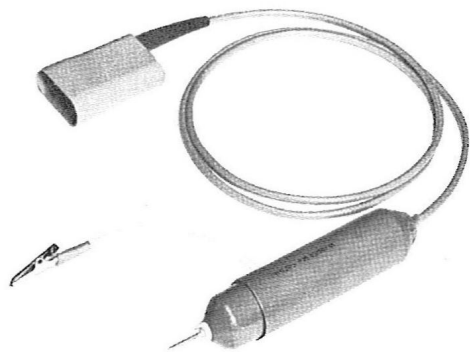

Fig. 2

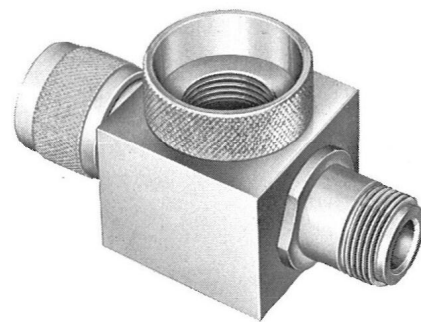
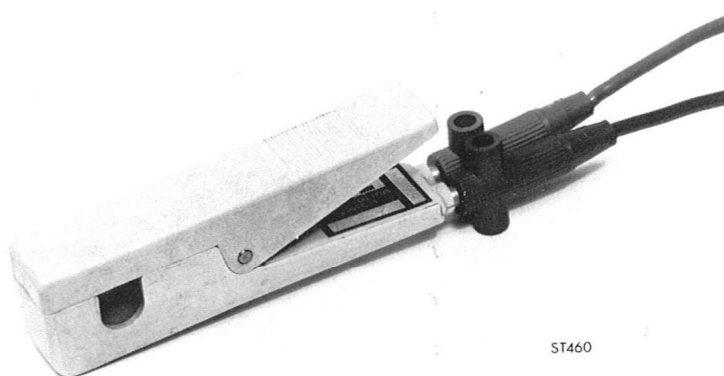

Fig. 3



ST460

Fig. 4



ST461

Fig. 5

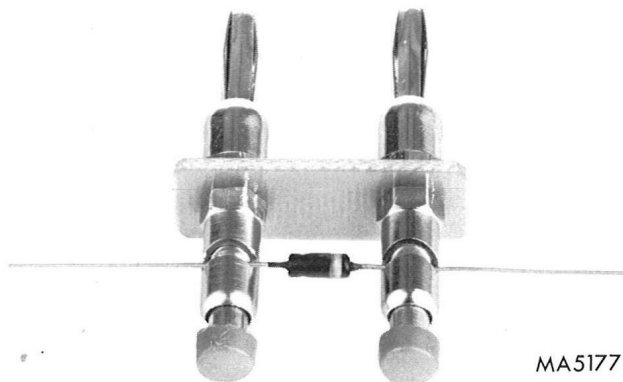

MA5177

Fig. 6

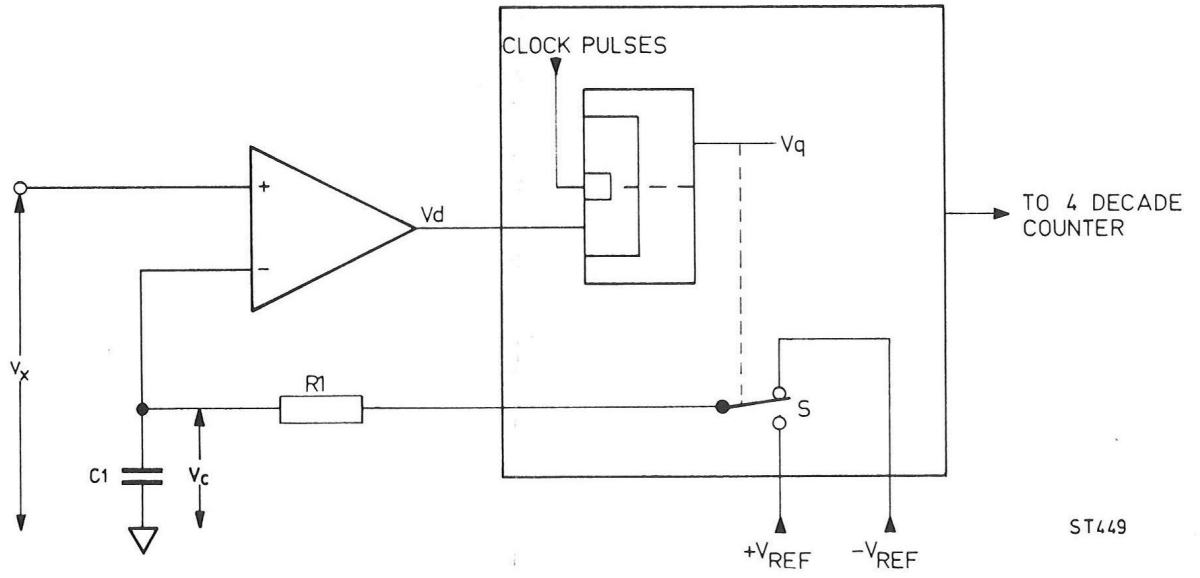

ST449

Fig. 7

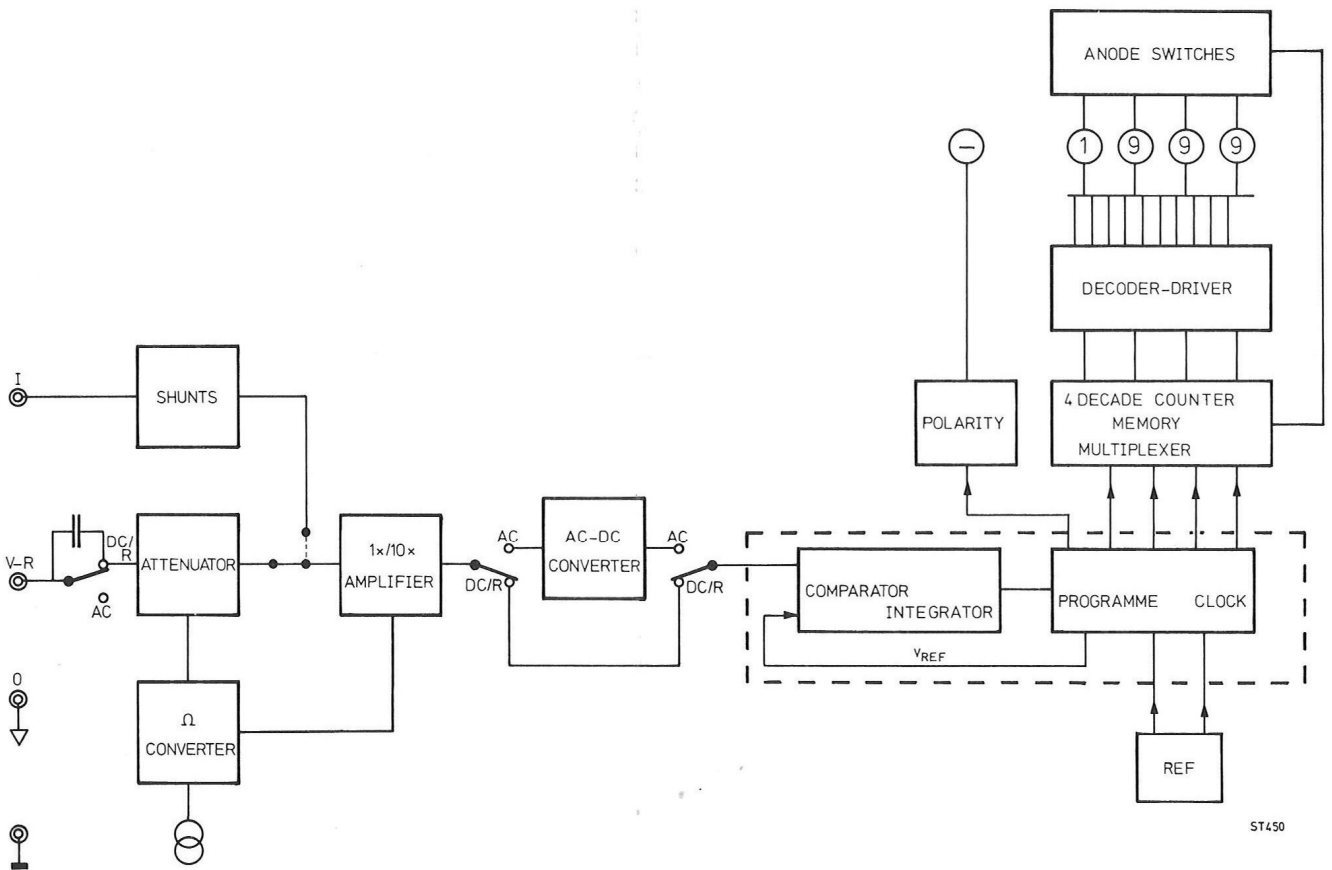

ST450

Fig. 8

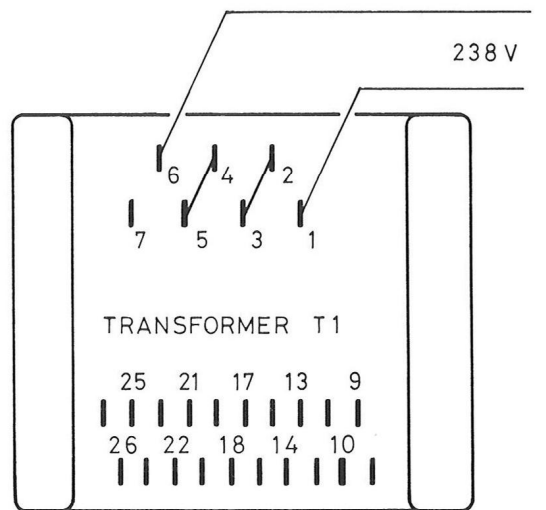
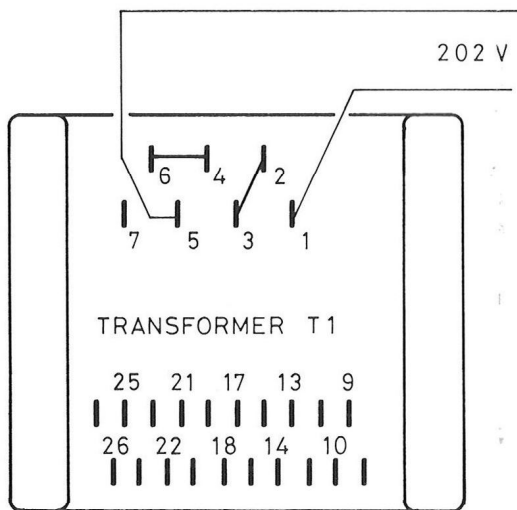
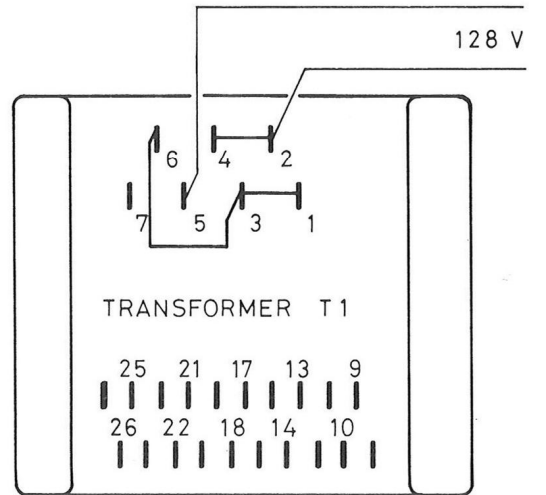
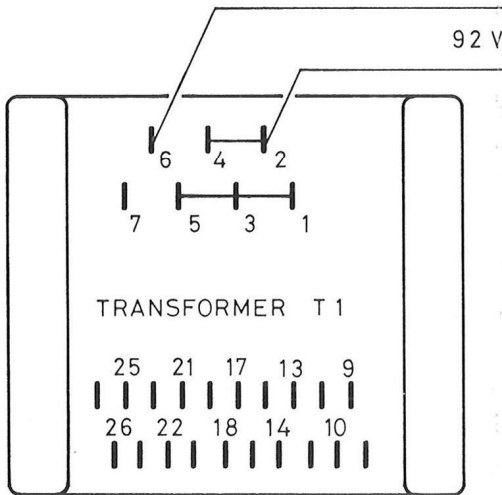
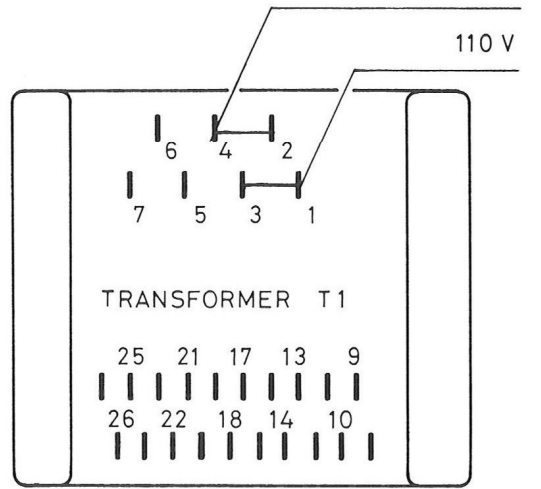
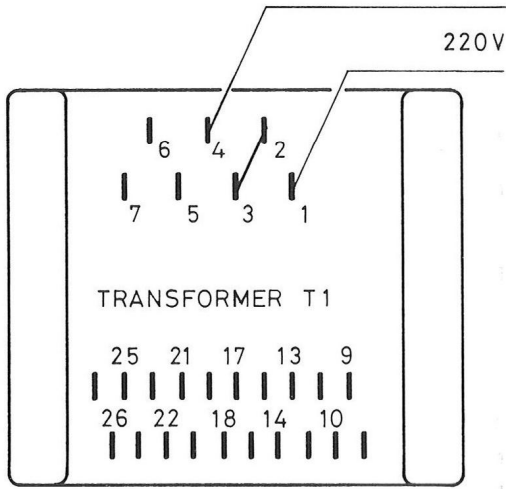

ST931

Fig. 9.

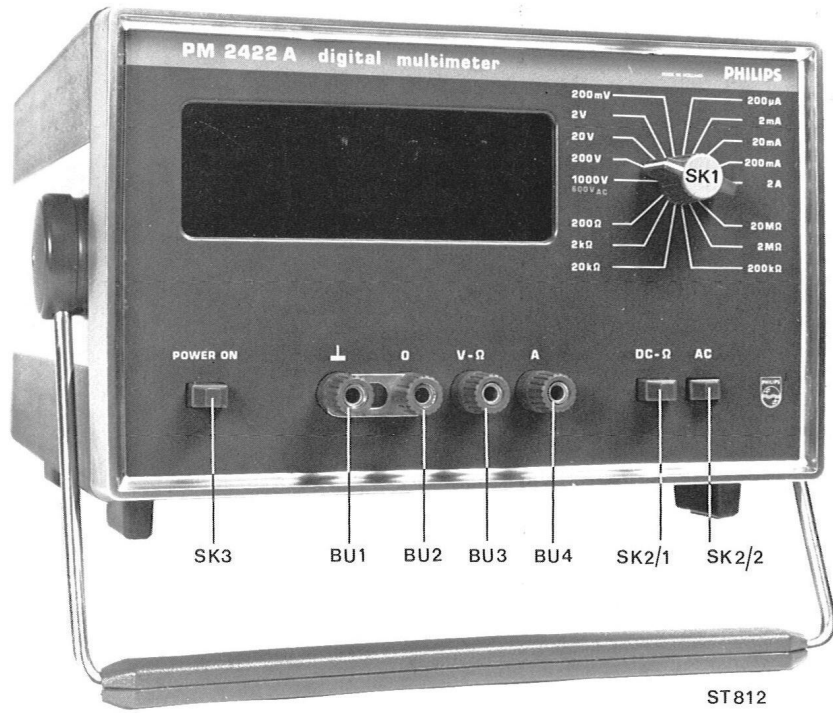

Fig. 10.

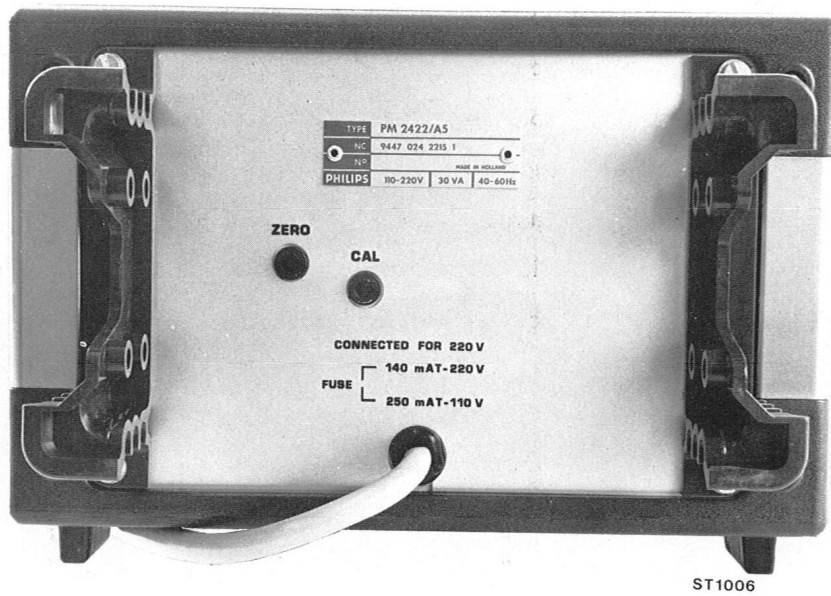

Fig. 11.

VII. CIRCUIT DESCRIPTION

SERVICE DATA

A. ANALOG SECTION

The analog section of the instrument serves to convert all modes to be measured into a voltage level of + or -2 V in order to obtain a maximum display.

This voltage is supplied to the digital section, which has a constant input-sensitivity of 2 V for maximum display.

1. DC voltage circuit

The input circuit for direct voltage measurements is shown in Fig. 12. The attenuation for the various ranges is given in the table below.

Range	Attenuation	Input amplifier (at end-of-range)
200 mV	1x	0.2 V
2 V	1x	2 V
20 V	100x	0.2 V
200 V	100x	2 V
1000 V	1000x	1 V

The attenuated input voltage is supplied to an amplifier, the gain of which is switchable between 1x and 10x by means of wafer SK1/II f. The output voltage of the amplifier is always 2 V at end-of-range. Spark-gap VL102, which conducts at voltages over 1700 V, serves to protect switch SK1.

2. AC voltage circuit

The circuit for alternating voltage measurements is shown in Fig. 12 and is in principle equal to the circuit for direct voltage measurements.

However, for the a.c. behaviour the attenuator resistors are shunted by capacitors C101 up to C105. After being amplified 1 or 10 times the alternating voltage (always 2 V a.c. at end-of-range) is supplied to an a.c.-to-d.c. converter.

The output direct voltage is supplied to the analog-to-digital converter.

3. Direct and alternating current circuit

The circuit for current measurements is shown in Fig. 13.

The current to be measured is converted into a voltage by means of shunts (R116 ... R120).

The voltage across the shunt is 0.2 V at end-of-range, thus the 1x/10x amplifier is set to position 10x for all current ranges.

For alternating currents the a.c.-to-d.c. converter is switched in after the amplifier.

The current ranges are protected by a 6A-fuse (VL103)

If the voltage across the shunt, caused by too high a current or by supplying an excessive voltage to the current input, is larger than about 1.4 V diodes GR101/GR103 or GR102/GR104, depending on the polarity, become conductive. The current through the diodes is restricted by R112 up to R115.

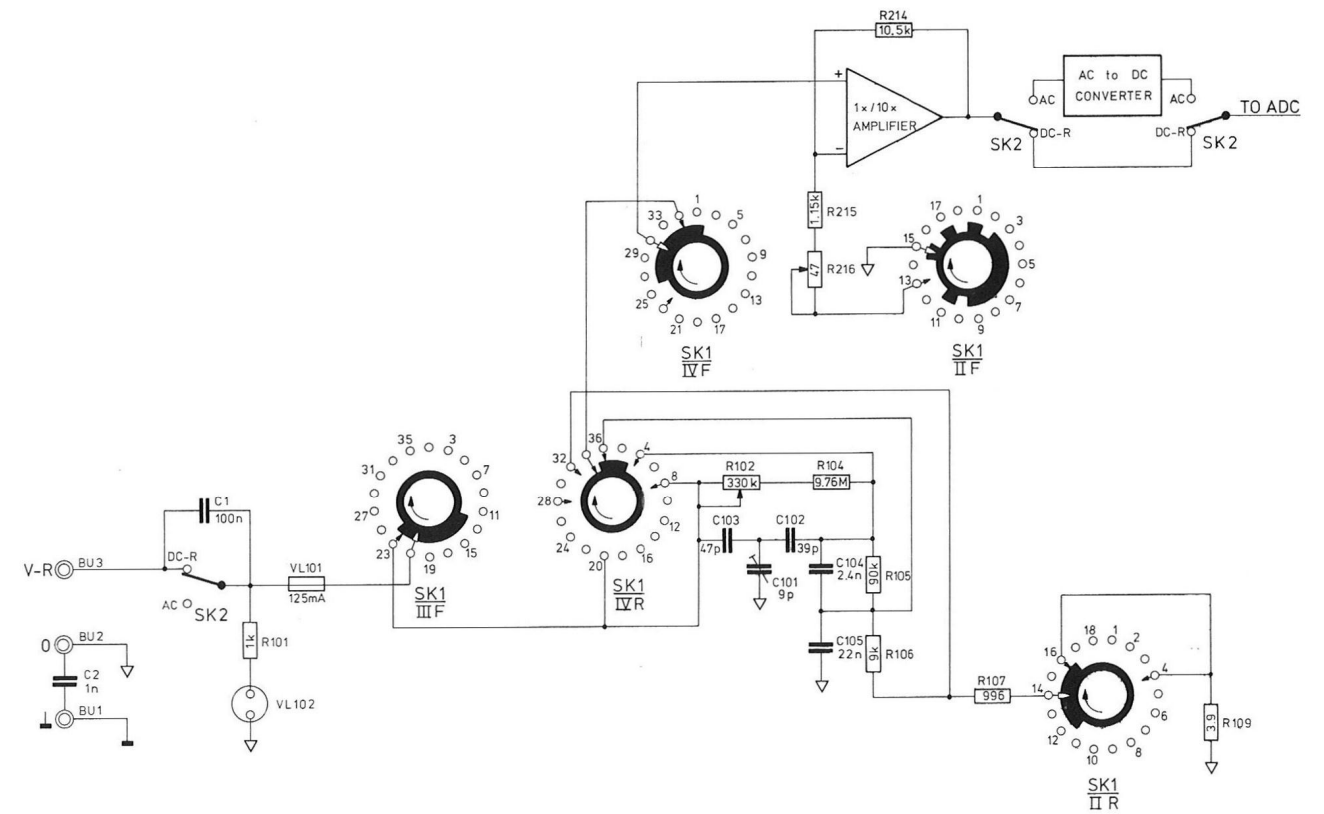

Fig. 12. Direct and alternating voltage measuring circuit

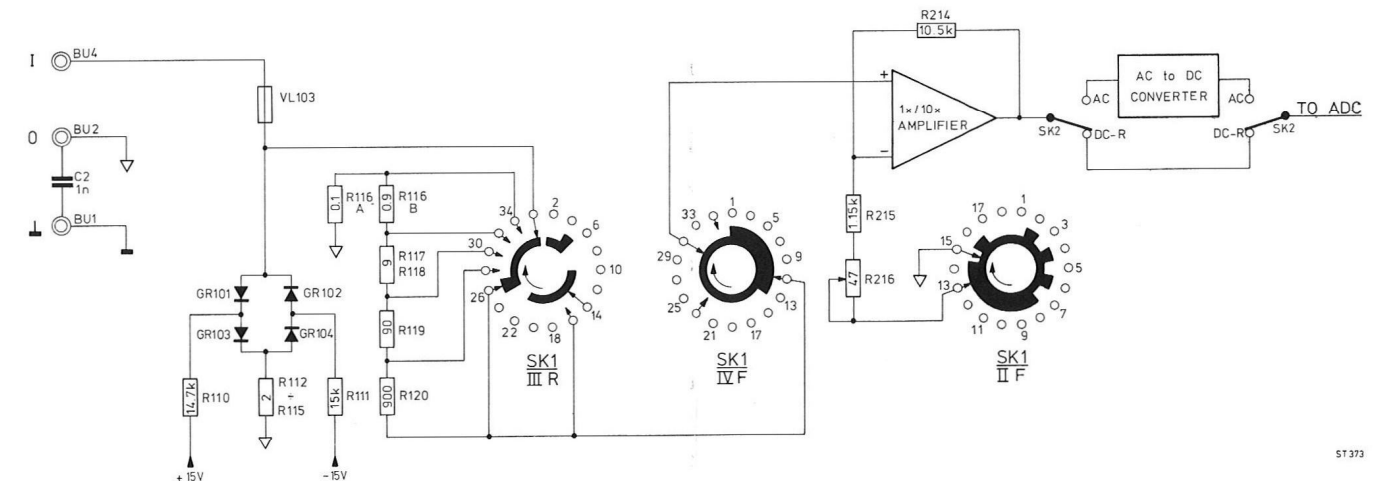

Fig. 13. Direct and alternating current measuring circuit

4. Resistance measuring circuit

The principle for resistance measurements is shown in Fig. 14.

A constant current passes through the unknown resistance R_x .

The voltage obtained across R_x is a measure for the value of R_x .

The voltage across R_x , V_x , is supplied to the + input of IC2 (1x/10x amplifier). Depending on the position of switch S, V_x will be amplified 1 or 10 times.

As the difference between both inputs is zero (for an ideal operation amplifier) voltage V_x is also available at the - input of IC2, which is interconnected with the + input of IC1. At the - input of IC1 a constant current source (1 mA) is connected.

As no current flows from the - input of IC1 the current of 1 mA causes a voltage of 1 V across the 1 k Ω -resistor. At the output of IC1 is present : V_x (from the + input) + 1 V (across 1 k Ω -resistor).

Thus a voltage of $V_x + 1 \text{ V} - V_x = 1 \text{ V}$ is available across R_s ; this voltage is independent of V_x and thus of R_x . Resistor R_s determines the current through R_x .

Fig. 15 represents the situation how this principle is used in the PM 2422A.

The next table gives a survey of the various measuring currents and voltages for the selected ranges.

Range	Value of R_s	Composition of R_s	Measuring current	Measuring voltage at end-of-range	1x/10x ampli- fier	ADC input
20 M Ω	10 M Ω	R107+R106+R105+	100 nA	2 V	1x	2 V
2 M Ω	10 M Ω		100 nA	200 mV	10x	2 V
200 k Ω	100 k Ω	R107+R106+R105	10 μ A	2 V	1x	2 V
20 k Ω	100 k Ω		10 μ A	200 mV	10x	2 V
2 k Ω	1 k Ω	R107 + resistance value of VL101 (approx. 4 Ω)	1 mA	2 V	1x	2 V
200 Ω	1 k Ω		1 mA	200 mV	10x	2 V

All resistance ranges can withstand 250 V a.c. at the input.

In the case of incorrect operation in the ranges 200 Ω and 2 k Ω the applied voltage appears across resistor R107 and is also supplied to the output of IC401 via R107. The voltage across R107, however, is limited by zener diodes GR105/GR106 at a value of about 12 V. Resistor R108 limits the zener-current. If the current exceeds 125 mA, fuse VL101 will blow.

All other resistor ranges are protected because the current will be low due to the very high value of resistor R_s (100 k Ω and 10 M Ω). Fuse VL101 then will not blow.

The current source consists of TS401 and GR402.

Zener diode GR402 is chosen so that the variations of V_{BE} of TS401 at temperature variations are compensated for by the temperature coefficient of the zener diode.

5. 1x/10x Amplifier (Fig. 16)

The amplifier consists of operational amplifier IC201 preceeded by source-follower TS203.

This source-follower has a very high input-impedance at a low offset current. The offset voltage of the amplifier is compensated for by R212 and potentiometer "ZERO" (R208) at the rear panel. With the latter potentiometer also the drift of TS203 can be compensated for.

The gain of the amplifier is determined by ratio

$$\frac{R214 + R215 + R216}{R215 + R216} = \frac{R214}{R215 + R216} + 1.$$

If switch S (corresponds to SK1/II f) is open the gain is 1 time, if it is closed the gain is 10 times.

With potentiometer R216 the gain can be adjusted to 10 times exactly.

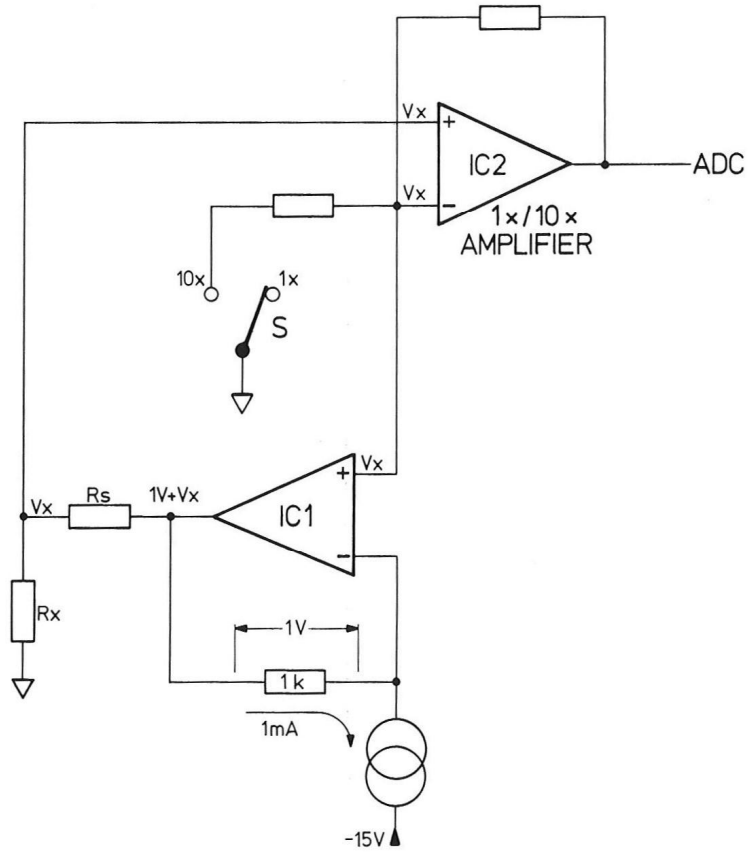

Fig. 14. Principle of resistance measurements

ST 367

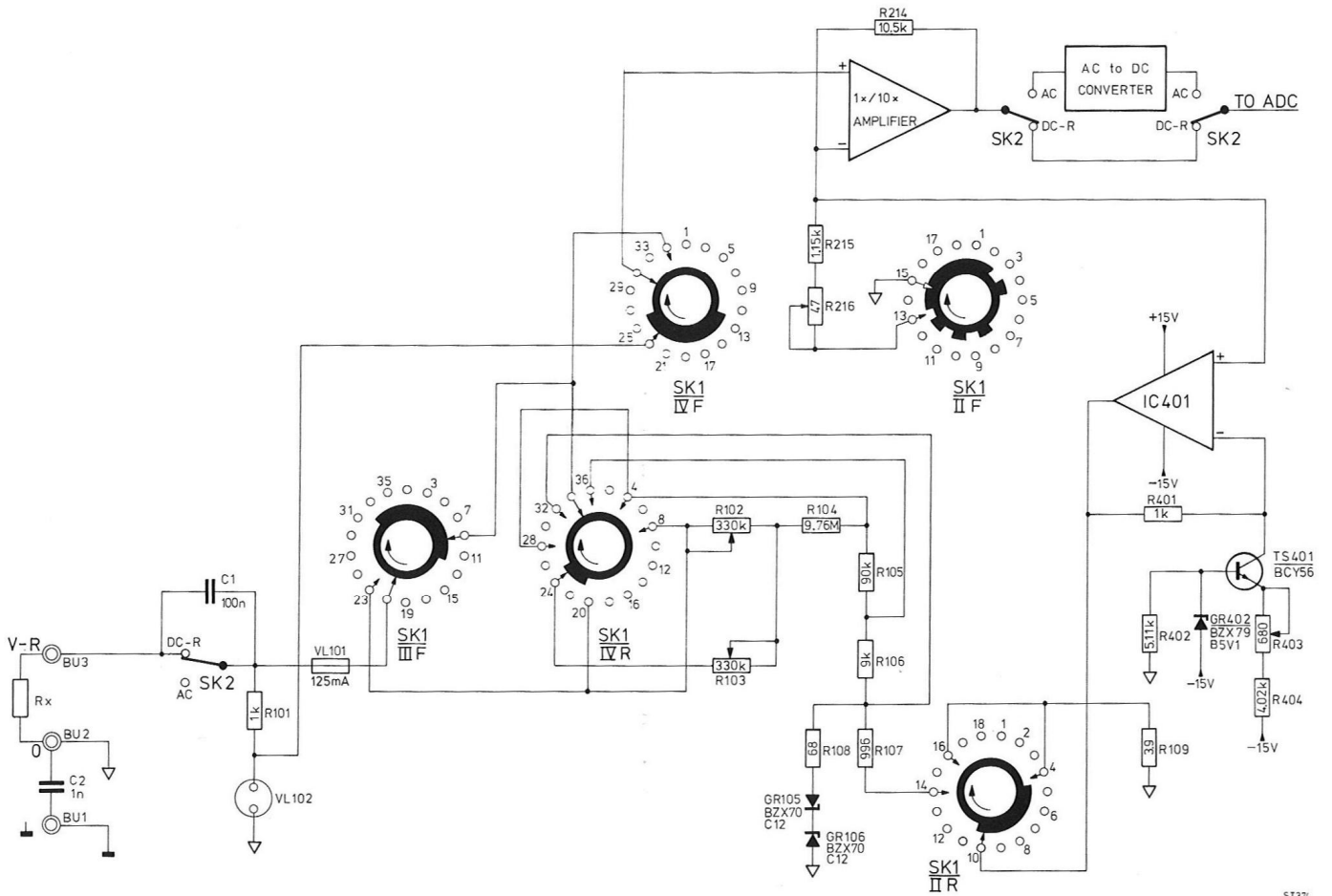

Fig. 15. Resistance measuring circuit

5137c

For d. c. measurements capacitor C203 is connected to circuit zero via FET switch TS204, thus forming together with R201 and R202 an RC-filter by which a. c. voltages are suppressed.

For a. c. measurements an improvement of the frequency response is achieved by $C201 + C202 // R202$.

The gate-leakage current of TS203 is kept low by making the source-drain voltage low by means of zener diode GR201.

Protection

The protection of the amplifier is made by transistors TS201 and TS202. By connecting bases and collectors two zener diodes are obtained the zener voltage of which is approximately 8 V with a low leakage current. If the voltage at point TP202 exceeds 8 V the transistors become conductive and limit the gate-voltage of TS203.

The input current is limited by R201 and R202.

6. AC-to-DC converter (Fig. 17)

The supplied voltage which is always $2 V_{r.m.s.}$ at range-end-values in all ranges is converted to 2 V d. c. To eliminate the non-linearity of the diode characteristic an operational amplifier with a high open-loop gain is used (IC301).

The gain for positive periods is determined by the ratio $\frac{R309}{R301 + R302}$, for negative periods by the ratio $\frac{R308}{R301 + R302}$ and should be 2.22 (twice the form factor).

As IC301 is controlled at the inverting input the input impedance of the converter is low (about 4.5 k Ω). However, the converter is preceded by the 1x/10x amplifier which serves as a buffer.

A separate d. c. feedback branch (R303-R306) is used to decrease the drift of IC301. However, it is decoupled for a. c. by C307.

Offset compensation is made by potentiometer R304 and indirectly used to adjust the linearity at small input voltages.

Potentiometer R302 is used to make end-of-range calibration.

B. DIGITAL SECTION

The digital section of the instrument serves to convert the supplied d. c. voltage from the analog section into a decimal information corresponding to the input signal.

The digital section contains the following circuits:

- $+V_{REF}$ and $-V_{REF}$.
- Analog-to-digital converter (ADC)
- Display

1. $+V_{REF}$ and $-V_{REF}$ (Fig. 18)

These voltages are required as reference voltage for the ADC.

The positive reference voltage is achieved via zener diode GR602 (50 ppm/ $^{\circ}$ C) controlled from a current source. With voltage divider R603 + R604 + R605/R608 an output voltage of 2.046 V is obtained which can be adjusted by potentiometers R603 and R604 (available at the rear).

The negative reference voltage is achieved by inverting $+V_{REF}$ via an amplifier with a gain of -1. Potentiometer R612 can be used to correct differences in "on" resistances and switching times of the switches in the ADC.

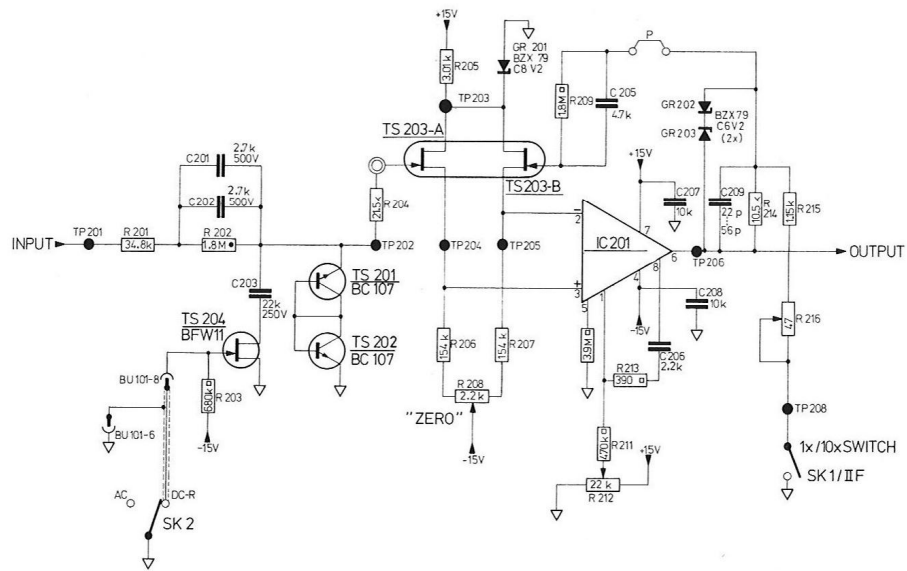

5T 368

Fig. 16. 1x/10x Amplifier

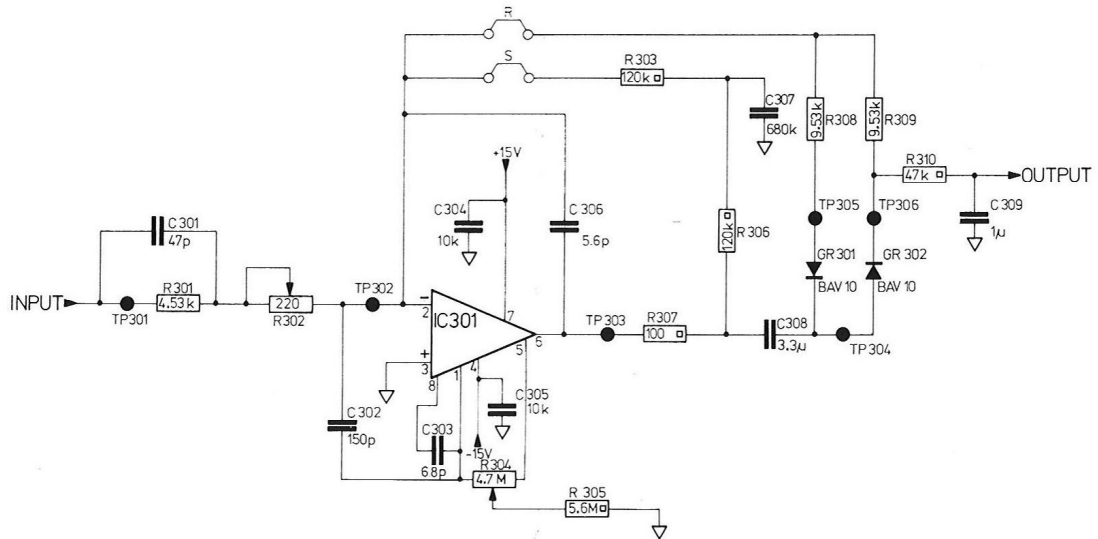

5T 370

Fig. 17. AC-to-DC converter

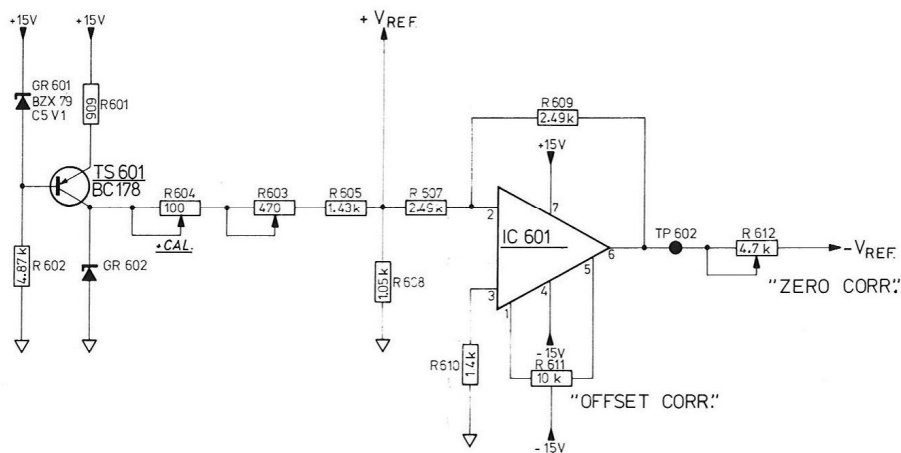

5T 364

Fig. 18. +V_{REF} and -V_{REF} circuit

2. Analog-to-digital converter (ADC)

The used system is derived from the delta pulse modulation principle.

For the function of the ADC, refer to chapter IV, sub-point B.

Practical execution

In PM 2422A this system is obtained as shown in Fig. 19.

The comparator consists of TS501 with a constant current source (TS502) followed by an amplifier (IC501) fed back for a.c.

The subtracting of pulses as described before is effected by an up-down counter which is included in IC502. This (P-channel-MOS) integrated circuit comprises also the next circuits:

- Input flip-flop, connection point 3.

This flip-flop sets the analog switches, which select the reference voltage.

- Analog switch: input at point 16 ($+V_{REF.}$) and point 14 ($-V_{REF.}$), output at point 15.

- Synchronisation circuit:

input : point 13

outputs : the reset pulse (11)

the transfer pulse (4)

the scan pulse (2)

If the input becomes logical 0 the measuring cycle is started at the first positive edge supplied by the input flip-flop, so that jitter and stalling of the digital part of the ADC are prevented.

- Polarity output circuit, output 12.

This circuit detects the polarity of the input voltage. If the output is logical 1 the polarity is negative; if, however, it is logical 0 the polarity is positive.

- Pulse output circuit, output 5.

During the measuring time, the ADC pulses are supplied to the display via output 5.

Remark

The scanning output supplies a signal with a frequency of 512 Hz and a duty cycle of about 1:15 at a clock frequency of 8.2 kHz.

This 512 Hz pulse feeds the scanning system of the display.

3. Clock oscillator (Fig. 20)

The clock pulse is derived from the programmable U. J. T. TS503.

The oscillator frequency is adjustable with R515. This frequency should be 8.2 kHz. By this the frequency of the scanning output of IC502 will be 512 Hz.

4. Display

The display is divided in the following blocks

- 4-decade counter/register (multiplexed output)
- decoder driver
- anode switches
- overrange detector

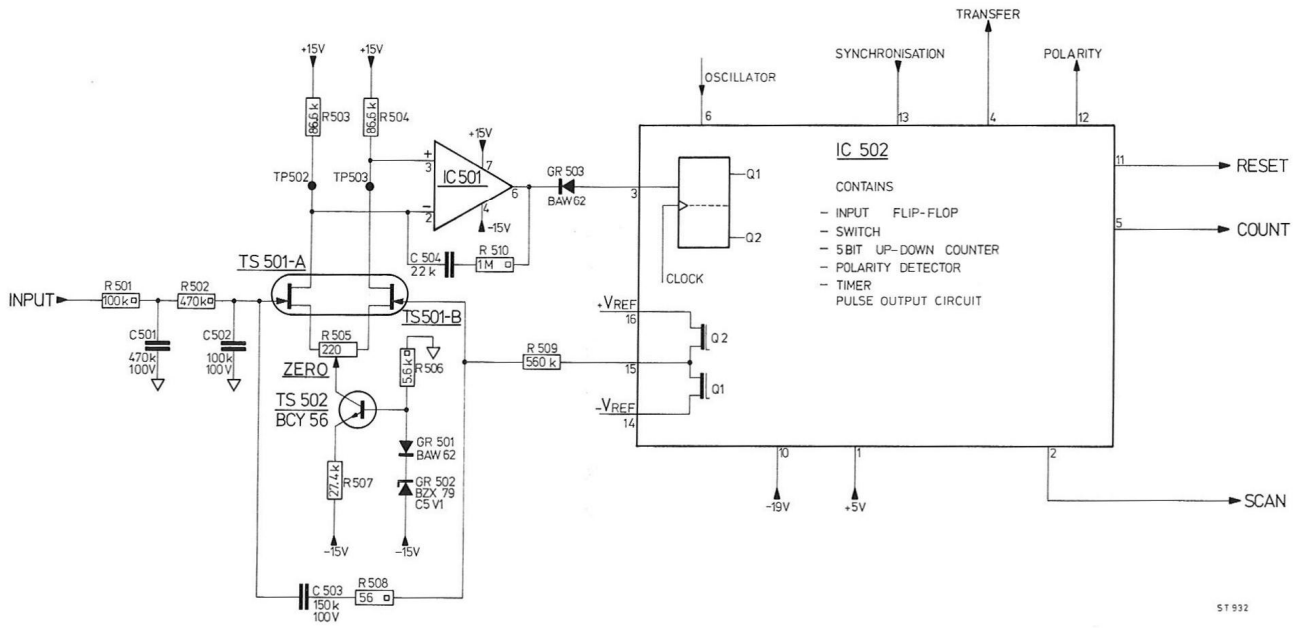

Fig. 19. Analog-to digital converter

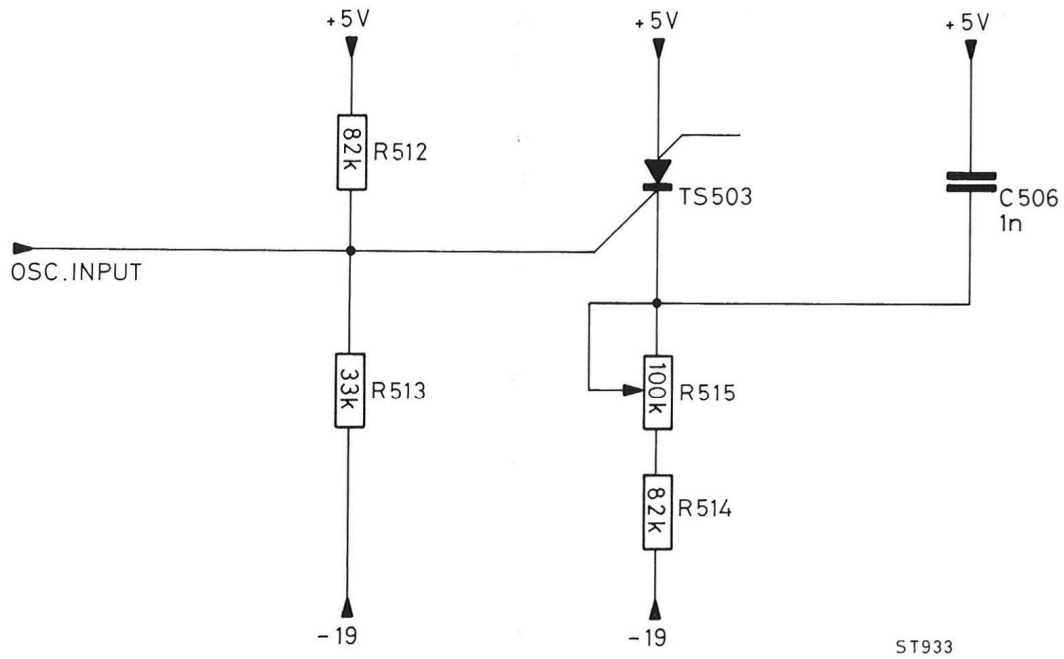

Fig. 20. Monostable multivibrator

a. 4-decade counter/register (Fig. 21)

This counter is a monolithic (P-channel-MOS) integrated circuit and contains

- four decade counters connected in series in such a way that the supplied pulses are converted into a BCD-code per decade.
- four buffer-registers which store the digital information from the decade counters.
- a multiplexer which converts the BCD parallel information into a serial form and transfers the digital information to the input of a decoder-driver synchronously with the relevant anode switch.
- a scaler-of-four which converts the scan frequency with a decoder, by means of a 1 out 4 code to drive the anode switches.

b. Decoder driver

The decoder driver converts the supplied BCD information into a decimal figure and controls the indicators 10^0 , 10^1 , 10^2 and 10^3 from which the cathodes are parallel-connected.

c. Anode switches (Fig. 22)

The indicators are controlled via 4 anode switches (TS707...TS710), which in turn are driven by signals "Scan 10^3 ", "Scan 10^2 ", "Scan 10^1 " and "Scan 10^0 " supplied by IC701 (see 4.a.).

Via a differentiating network (e.g. C702-R716) pulse "Scan 10^3 " (a negative pulse) is applied to the base of TS707. The negative-going edge turns on TS707; thus the corresponding indicator anode (10^3) is connected to the +185 V supply.

At the positive-going edge TS707 is blocked.

GR710/GR712/GR714/716 limit V_{BE} of the anode switches at the positive edge; while GR713/GR715/GR718 limit the V_{CE} .

To block the transistors TS707...TS710 the emitter is biased with respect to the base by means of stabistor GR717.

Sequence diagram Fig. 23 gives a short survey of the working.

d. Overrange detector (Fig. 24)

If the read-out exceeds 1999 the overrange detector detects both the logical levels of signals DATA OUT "B" (logical 1) and SCAN 10^3 (logical 0). The output voltage of the detector becomes logical 1 (5 V) thus blocking the pulses SCAN 10^0 and SCAN 10^1 . The corresponding indicators extinguish. Only indicator B703 (10^2) lights and shows a 0 because the maximum display is 2046. Furthermore the "2" indication for the thousands is not built in.

C. SUPPLY (Fig. 35, blz. 67)

1. +185 V source

This source serves to supply the indicators (B702...B705) and is stabilized via a series-stabilisation circuit.

The reference voltage, derived from zener diodes GR806 and GR807, serves also to clamp maximum V_{CE} of the transistor switches TS707...TS710.

Zener diode GR805 and resistor R815 serve to limit the load current, as the current supplied to the decoder-driver amounts to 7 mA max. (at $V_{QL} = 0$ V).

The voltage across C807 (+230 V) is used to supply LA701 ("-" indicator).

2. +15 V and +5 V source

This source is stabilized via voltage regulator IC801 which comprises a reference amplifier, a control amplifier and a current limiting circuit.

The +5 V source is derived from the +15 V source with zener diode GR801 and transistor TS801. R801 serves for current limitation for transistor TS801.

3. -19 V and -15 V source

This source is stabilized via voltage regulator IC802. The output current is limited by zener diode GR804 and series resistor R811.

The -15 V source is derived from the -19 V source with stabistor GR809.

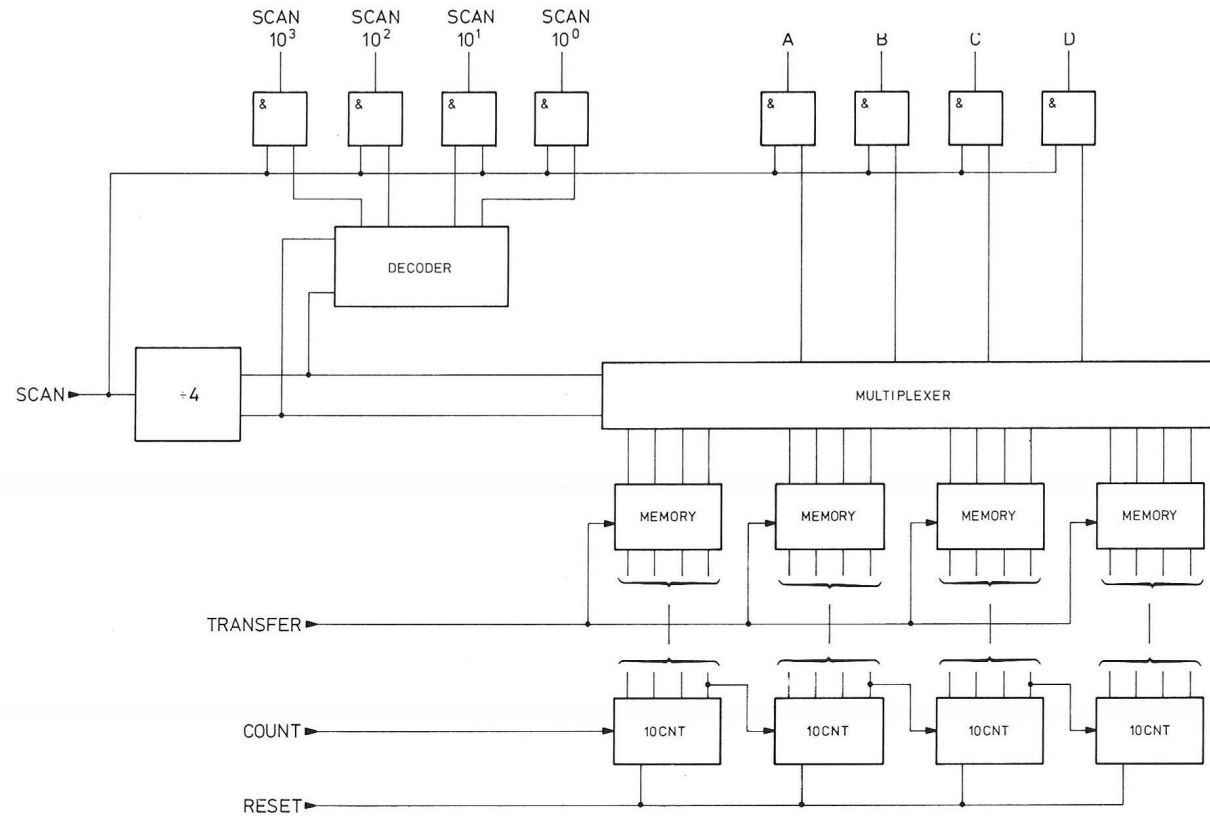

ST 372

Fig. 21. 4 Decade counter

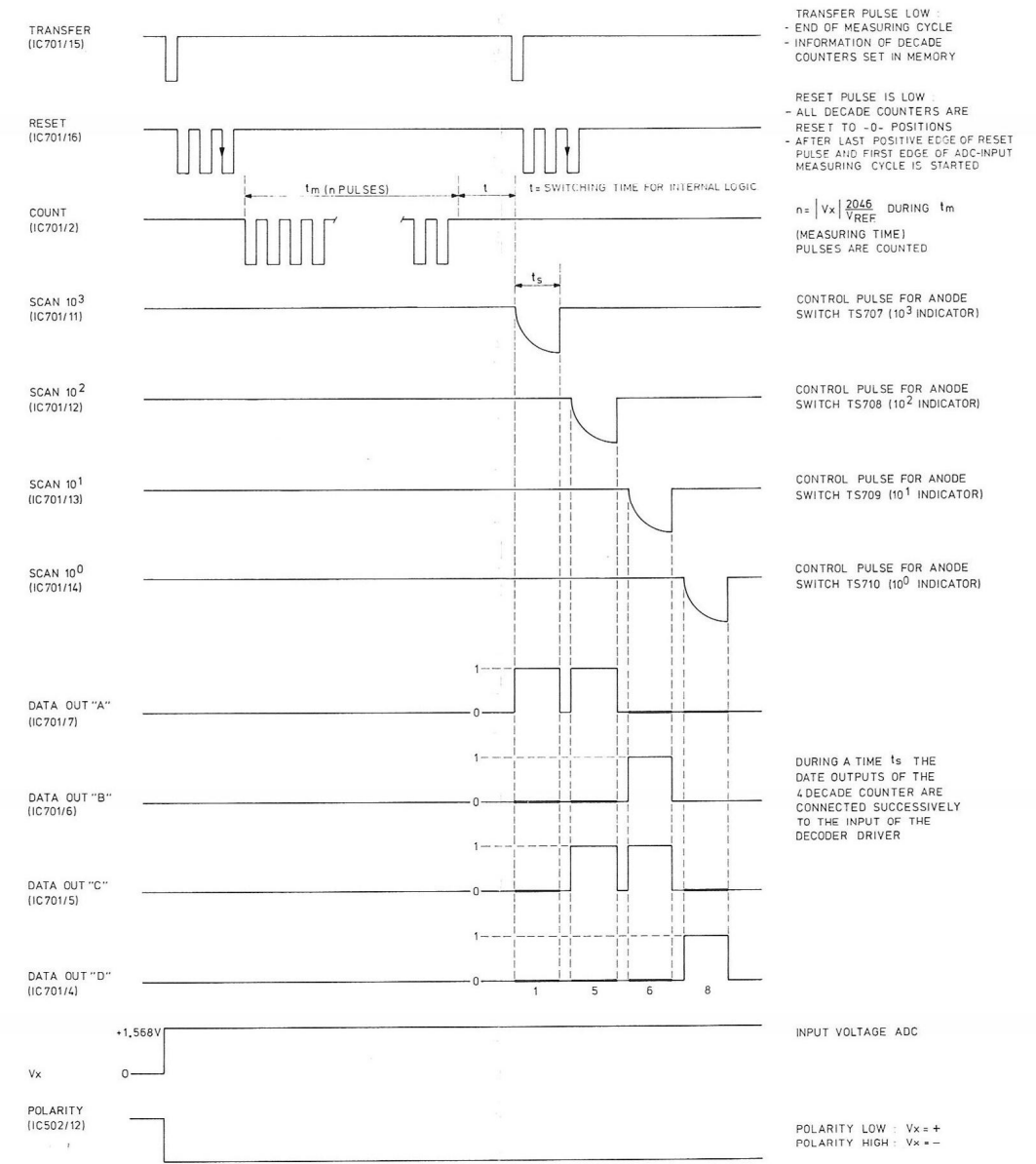

ST 934

Fig. 23. Sequence diagram

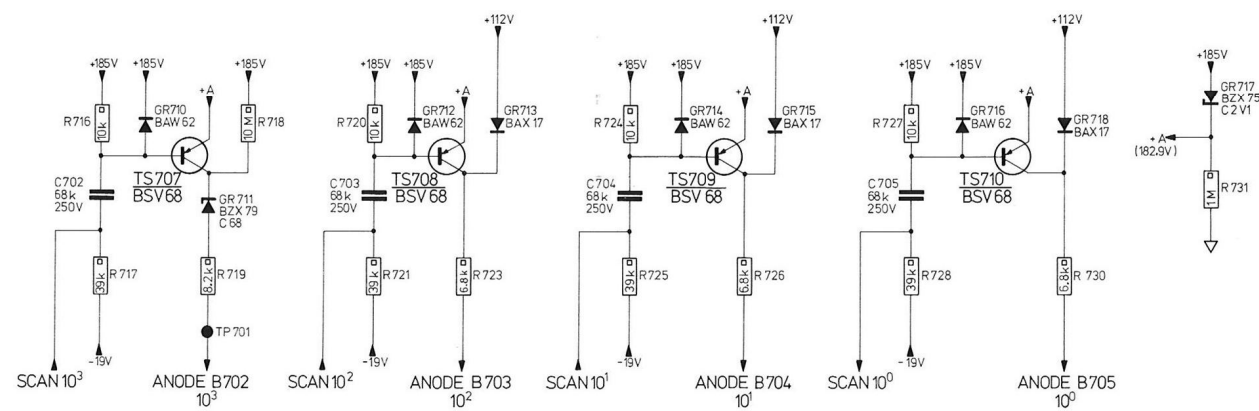

ST 355

Fig. 22. Anode switches

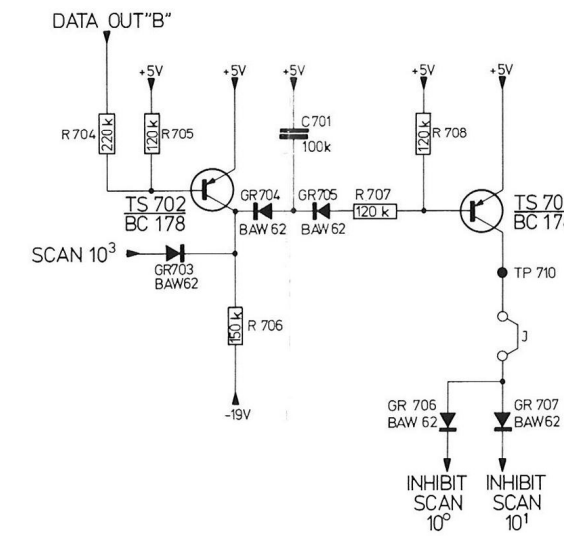

ST 369

Fig. 24. Overrange detector

VIII. ACCESS

The opening of parts, or removal of covers, is likely to expose live conductors. The instrument should therefore be disconnected from all voltage sources before any opening of parts or removal of covers is started.

During and after dismantling, bear in mind that capacitors in the instrument may still be charged even if it has been separated from all voltage sources.

USE A WELL-FITTING CROSSHEAD SCREW-DRIVER TO DISMANTLE THE INSTRUMENT TO PREVENT THE CROSS-SLOTTED SCREWS FOR DAMAGE.

A. DISMANTLING

1. Top cover

- Remove both screws "A" (Fig. 31).
- Lift the cover at the rear and slide it backwards from the unit.

2. Bottom cover

- Remove both screws "B" (Fig. 31).
- Lift the cover at the rear and slide it backwards from the unit.

B. FUSES

1. Fuse VL1

The mains supply is protected by fuse VL1 mounted inside on the rear plate (fig. 32, page 101).

2. Fuse VL101

In the resistance circuit fuse VL101 will protect the zener current. If the current exceeds 125 mA, the fuse will blow.

3. Fuse VL103

In the current circuit (via terminals I, BU4) a 6.3 A glass fuse has been incorporated to protect the shunt resistors R116-120.

C. ELECTRICAL COMPONENTS

If an electrical component (resistor, capacitor, transistor or integrated circuit) has been replaced by a new one, the relevant part of the circuit must be checked in accordance with chapter XI.

The next survey indicates roughly which sub-point(s) of chapter XI must be performed.

Part number	Adjust or check in accordance with
R102...R107 (Attenuator)	XI.D.4. , XI.F.1. and XI.F.2.
R116...R120 (Shunts)	XI.G.
C101-C105 (a.c. attenuator)	XI.E.4. and XI.E.5.
Components starting with sequence number 2..	XI.D.1. , XI.D.2. and XI.D.3.

Part number	Adjust or check in accordance with
Components starting with sequence number 3..	XI.E.1., XI.E.2. and XI.E.3.
Components starting with sequence number 4..	XI.F.1.
Components starting with sequence number 5..	XI.C.1., XI.C.2. and XI.C.3.
Components starting with sequence number 6..	XI.C.1., XI.C.2. and XI.C.3.

IX. MAINTENANCE AND SERVICE

Digital multimeter PM 2422A requires no maintenance because the instrument contains no components which are subject to wear.

However, to ensure reliable and faultless operation, the instrument should not be exposed to moisture, heat, corrosive vapours and excessive dust.

Service hints

If service work must be performed, the following points should be taken into account to avoid damage of the instrument.

- In case of measurements on a switched-on instrument proceed carefully to avoid short-circuits by means of measuring clips or measuring hooks
- For soldering use absolutely acid-free soldering tin
- For all soldering work on the printed circuit boards, use a miniature soldering iron (35 W max.) with a thin-cleaner or a vacuum soldering iron.

Trouble shooting

On the printed wiring board test points are introduced at the component side as well as at the conductor side. The test points at the component side (Fig. 25) are especially made for service work, those at the conductor side for testing purposes in the factory. The latter can, of course, also be used for servicing (Fig. 26).

Furthermore, jumpers are introduced on the printed wiring board (Fig. 27); they can be used to interrupt circuits in order to test the functioning of the corresponding circuit.

General conditions:

- nominal mains voltage (220 V, 50 Hz)
- calibrated
- voltages with respect to circuit zero (terminal "0"), unless otherwise stated
- the data given represent the properties of an average instrument and may serve as a guide only
- voltages are measured with digital multimeter PM 2421
- oscillograms are recorded with oscilloscopes PM 3370 and PM 3250
- measure voltages and oscillograms with 10 M Ω input impedance.

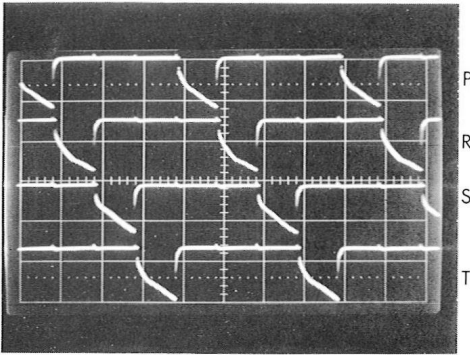

ST455A

I

P, R, S and T are the scanning outputs for controlling the anode switches

P = Scan 10^3
 R = Scan 10^2
 S = Scan 10^1
 T = Scan 10^0

Oscilloscope settings
 Amplitude : 10 V/cm
 Time base : 2 msec/cm

Oscillograms apply for no overload condition.

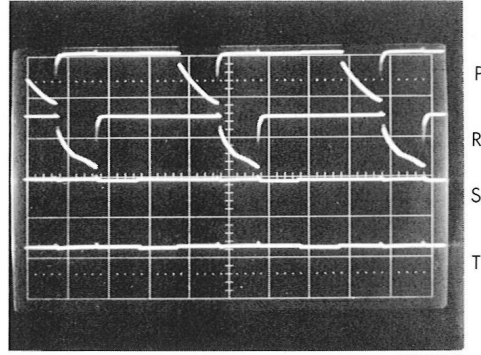

ST455B

II

P = Scan 10^3
 R = Scan 10^2
 S = Scan 10^1
 T = Scan 10^0

Oscilloscope settings
 Amplitude : 10 V/cm
 Time base : 2 msec/cm

Oscillograms apply for overload condition.

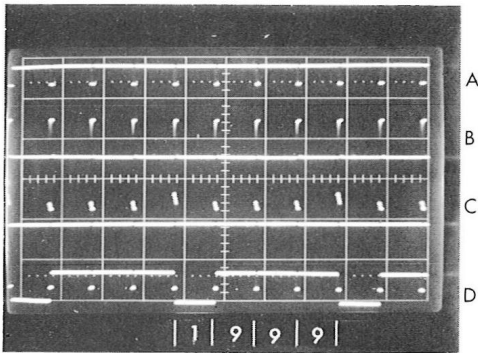

ST455C

III

A = Data out A (1)
 B = Data out B (2)
 C = Data out C (4)
 D = Data out D (8)

Oscilloscope settings
 Amplitude : 5 V/cm
 Time base : 2 msec/cm

Oscillograms apply for display 1999.

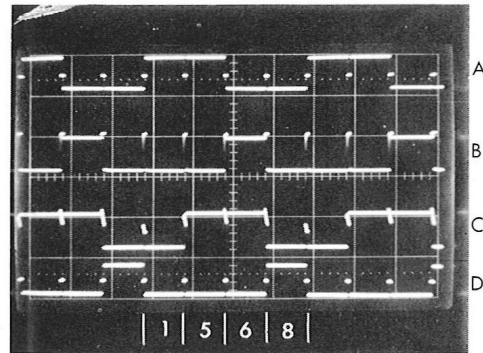

ST456A

IV

A = Data out 10^3
 B = Data out 10^2
 C = Data out 10^1
 D = Data out 10^0

Oscilloscope settings
 Amplitude : 5 V/cm
 Time base : 2 msec/cm

Oscillograms apply for display 1568.

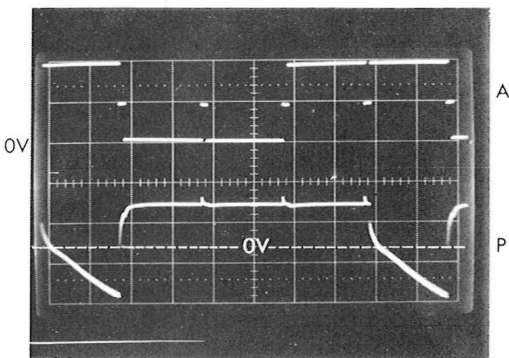

ST456B

V

A = Data out A
 P = Scan 10^3

Oscilloscope settings
 Amplitude A : 2 V/cm
 Amplitude P : 5 V/cm
 Time base : 1 msec/cm

Display 1568.

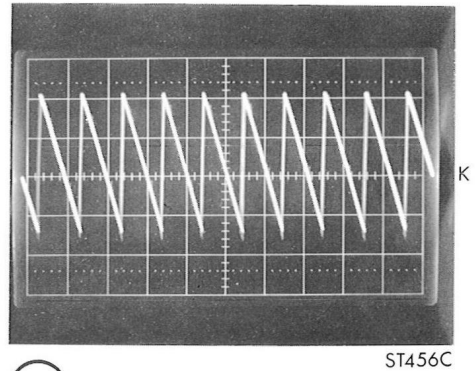

ST456C

VI
 Comparator output
 Oscilloscope settings
 Amplitude : 1 V/cm
 Time base : 2 msec/cm
 Input voltage ADC is 1.8 V

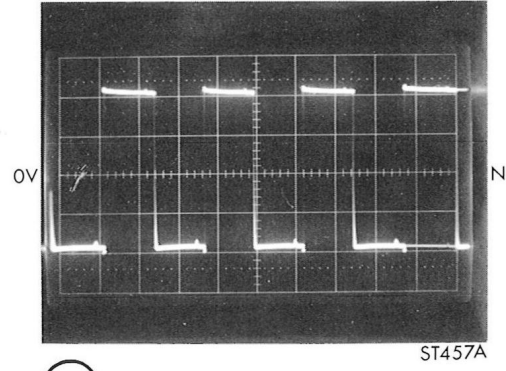

ST457A

VII
 Count
 Oscilloscope settings
 Amplitude : 2 V/cm
 Time base : 1 msec/cm
 2 V at input of ADC

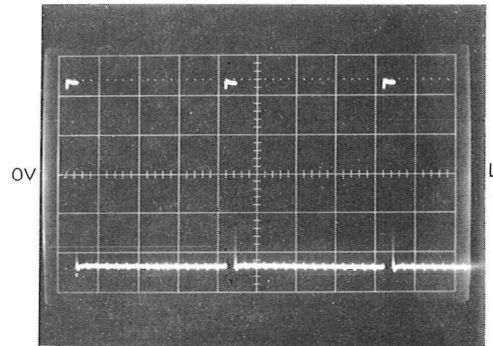

ST457B

VIII
 Scan in
 Oscilloscope settings
 Amplitude : 2 V/cm
 Time base : 0.5 msec/cm

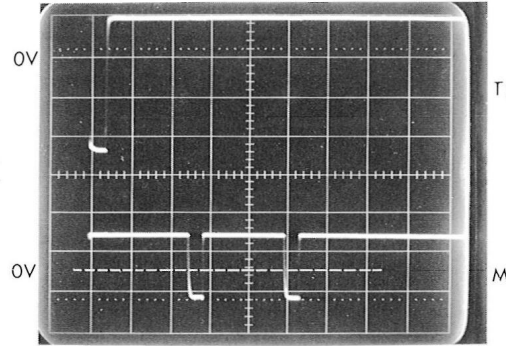

ST457C

IX
 TP711 = Transfer out
 M = Reset
 Oscilloscope settings
 Amplitude : 5 V/cm
 Time base : 50 μsec/cm

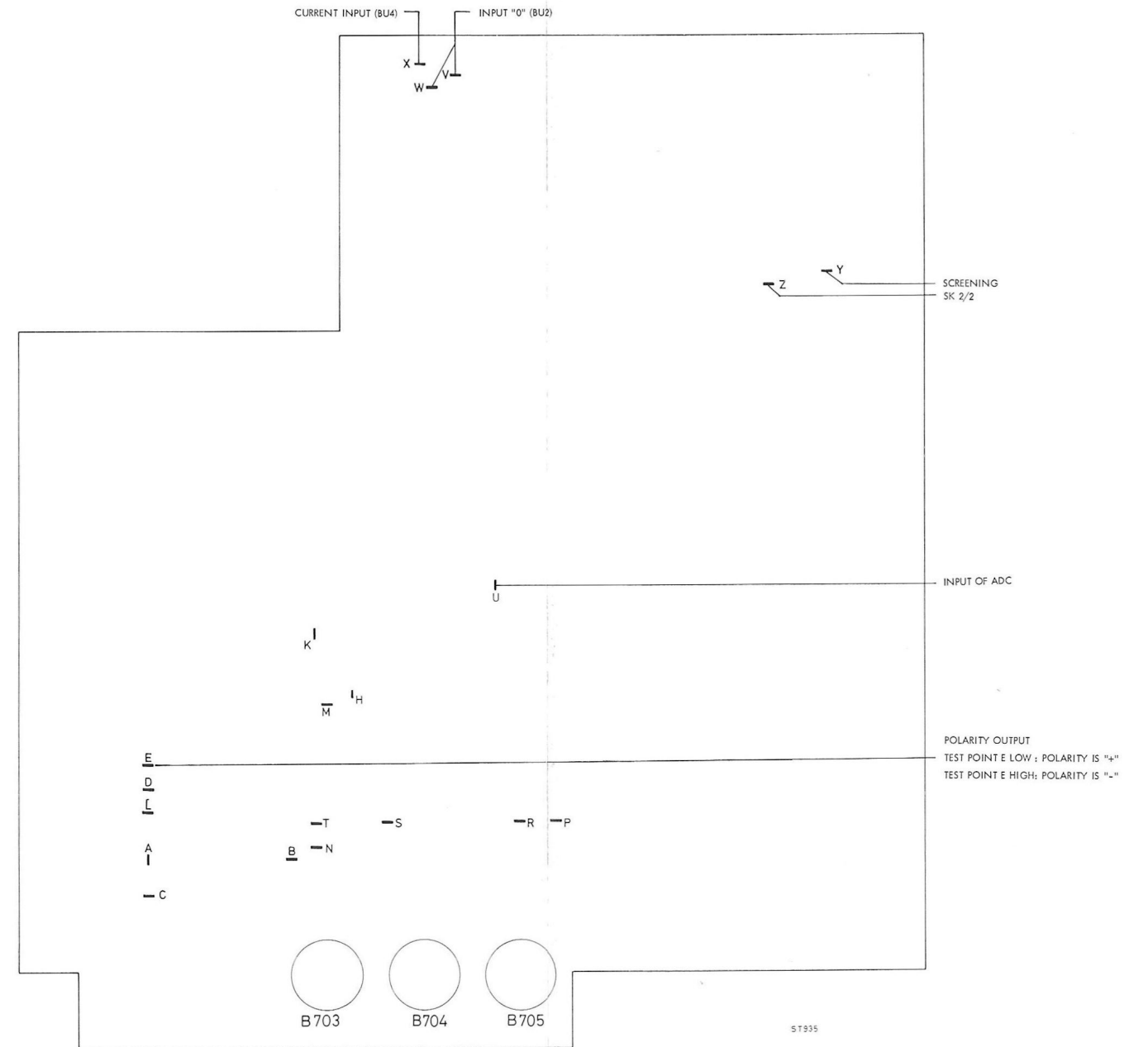
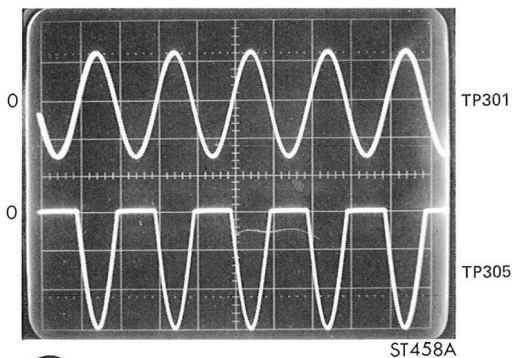

Fig. 25. Location of test points at component side of the printed wiring board.



(X)

TP301 Input a.c. -to-d.c. converter
TP305 Output neg. rectifier

Oscilloscope settings
Amplitude : 2 V/cm
Time base : 0.5 msec/cm

Input voltage : 1.994 V
Frequency : 1 kHz

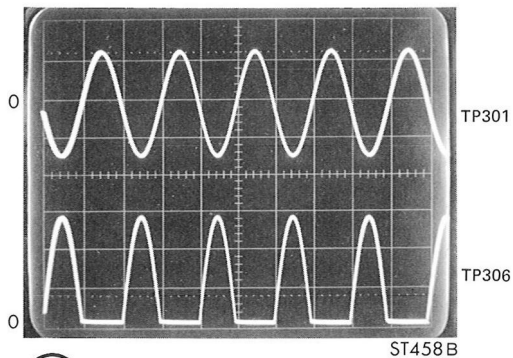

(XI)

TP301 Input a.c. -to-d.c. converter
TP306 Output pos. rectifier

Oscilloscope settings
Amplitude : 2 V/cm
Time base : 0.5 msec/cm

Input voltage : 1.994 V
Frequency : 1 kHz

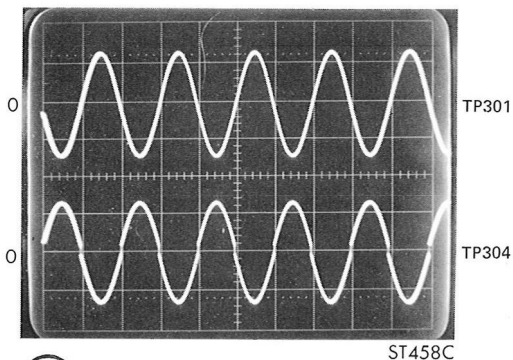

(XII)

TP301 Input voltage a.c. -to-d.c. converter
TP304 Output a.c. -to-d.c. converter

Oscilloscope settings
Amplitude:
TP301 2 V/cm
TP304 5 V/cm
Time base : 0.5 msec/cm

Input voltage: 1.994 V
Frequency : 1 kHz

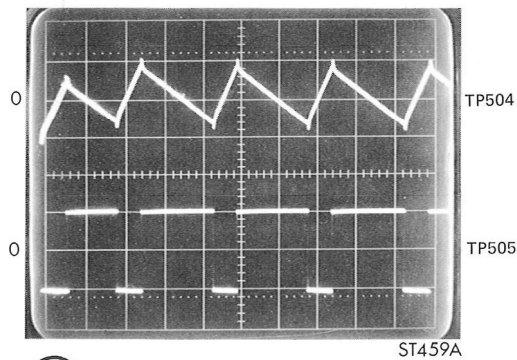

(XIII)

TP504 Output comparator
TP505 Chopped output reference

Oscilloscope settings
Amplitude : 2 V/cm
Time base : 0.2 msec/cm

Input voltage ADC : 1 V

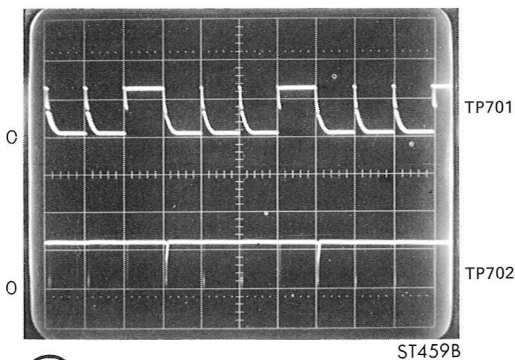

(XIV)

TP701 Anode LA702 (10^3 indicator)
TP702 Cathode LA702

Oscilloscope settings
Amplitude:
TP701 100 V/cm
TP702 50 V/cm
Time base : 2 msec/cm

Display 000

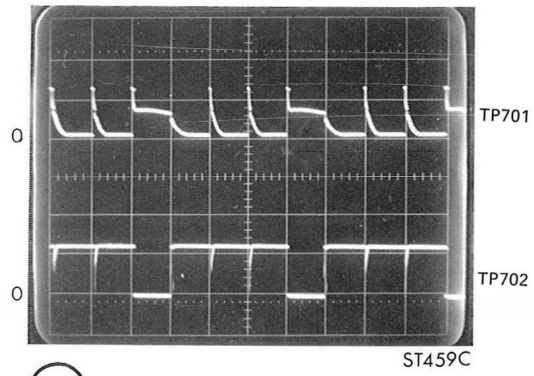

(XV)
ST459C

TP701 Anode LA702 (10^3 indicator)
TP702 Cathode LA702

Oscilloscope settings
Amplitude:
TP701 100 V/cm
TP702 50 V/cm
Time base : 2 msec/cm
Display 1004

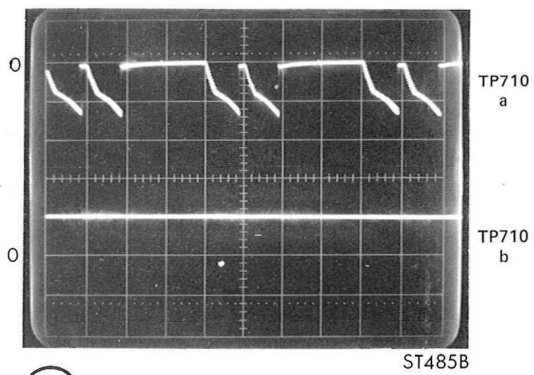

(XVII)
ST485B

TP710 a: No overrange
TP710 b: Overrange

Oscilloscope settings
Amplitude : 5 V/cm
Time base : 2 msec/cm

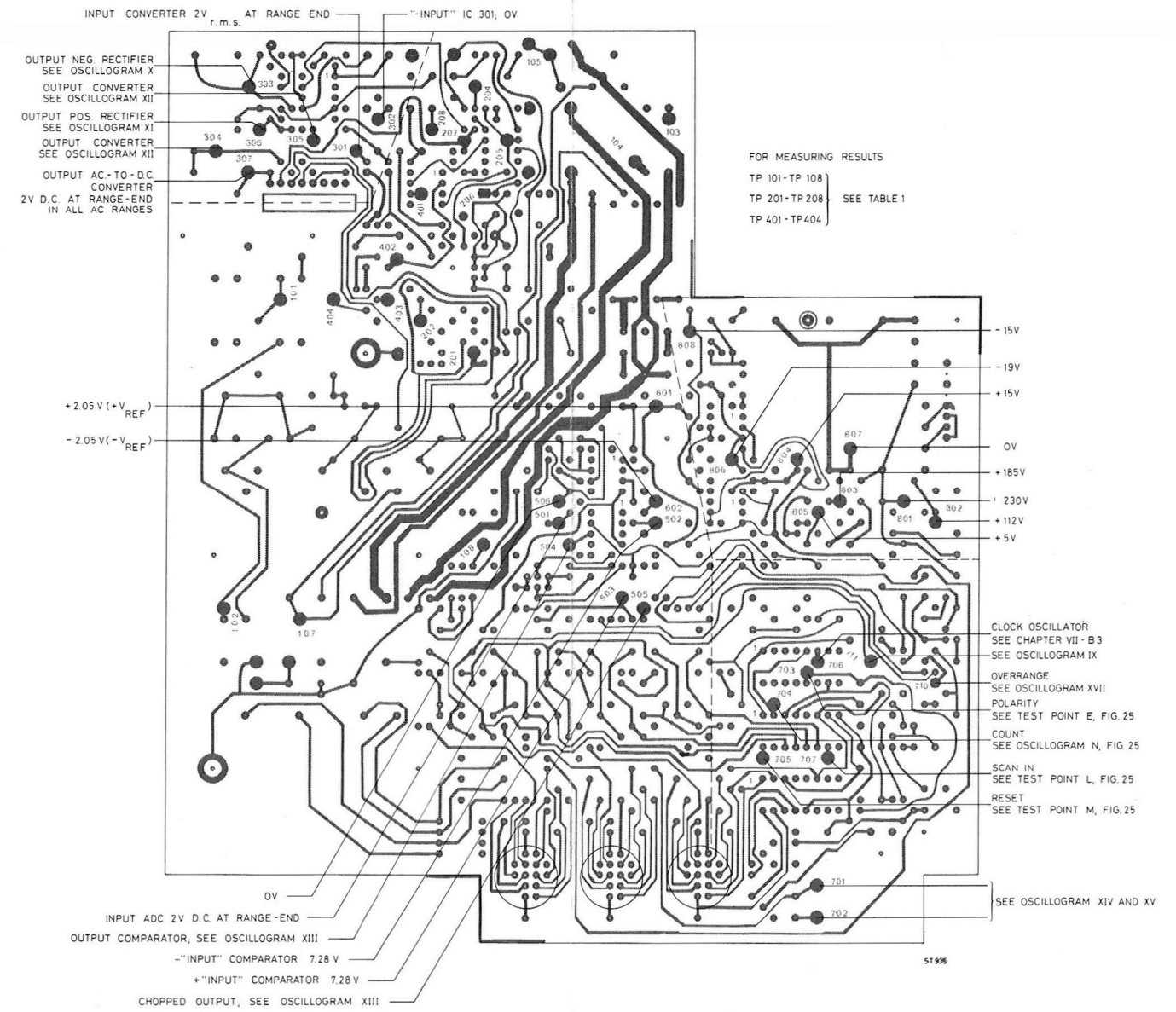

Fig. 26. Location of test points at conductor side of the printed wiring board.

XII. PARTS LIST

A. MECHANICAL

Item	Fig.	Qty.	Ordering number	Description
1	30	2	5322 447 94068	Top and bottom cover
2	30	1	5322 414 64039	Knob
3	30	1	5322 414 74019	Cap for knob
4	30	2	5322 535 74367	Spindle for handle
5	30	2	5322 498 74003	Cap for handle
6	30	1	5322 520 34139	Bearing bush, right
7	30	1	5322 520 34138	Bearing bush, left
8	30	4	5322 462 44121	Foot
9	30	4	5322 492 64338	Leaf spring
10	30	1	5322 498 54032	Handle
11	30	3	5322 414 14011	Knob for push button
12	30	4	5322 290 40011	Terminal BU1...BU4
13	30	1	5322 290 30001	Short-circuiting clip
14	30	1	5322 460 64002	Ornamental frame
15	30	1	5322 456 14031	Text plate
16	30	1	5322 459 24033	Window
17	31	2	5322 462 44175	Foot
18	31	1	5322 325 54029	Cable grommet
19	31	1	5322 321 14001	Mains cable
21	31	2	5322 532 64119	Guiding bush
22	32	1	5322 267 54041	8-pole contact block BU101
23	32	1	5322 273 84012	Switch SK1
24	32	1	5322 532 54209	Coppling piece
25	32	1	5322 535 94637	Extension spindle
26	32	3	5322 255 70145	Valve holder
27	32	1	5322 256 94046	Indicator housing
28	32	3	5322 255 44044	IC holder, 16 pin
29	32	2	5322 255 40079	Heat sink
30	32	1	5322 267 54038	8-pole contact socket BU102
31	32+33	2	5322 264 54006	Connector housing
32	32+33	13	5322 268 14013	Pin contact
33	32	1	5322 256 34021	Fuse holder
34	33	1	5322 276 10272	Mains switch SK3
35	33	1	5322 492 64337	Retaining spring
36	33	1	5322 535 94637	Extension spindle
37	33	1	5322 276 24016	Push-button switch SK2
38	6	1	5322 290 40077	Measuring terminal

^x See chapter VIII.C

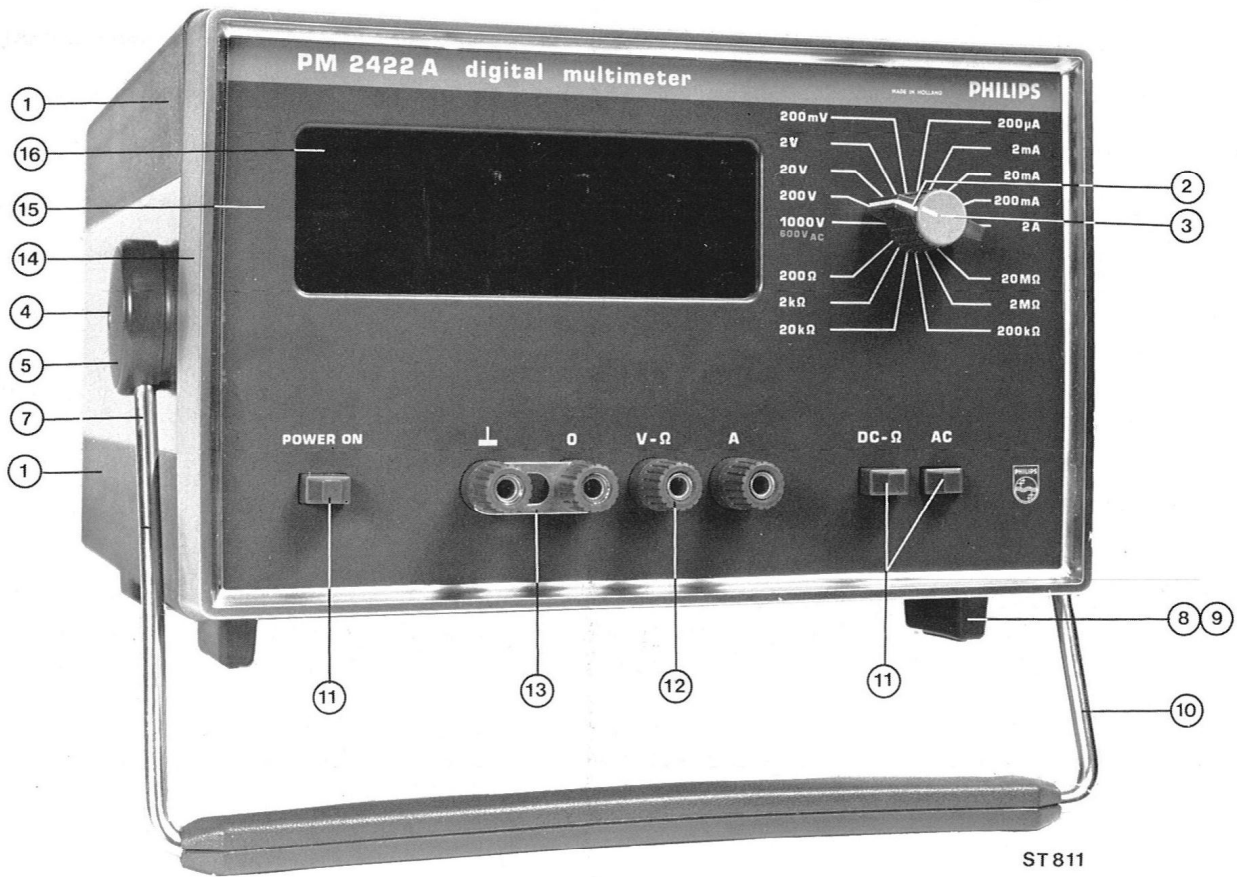

Fig. 30. Front view with indication of item numbers

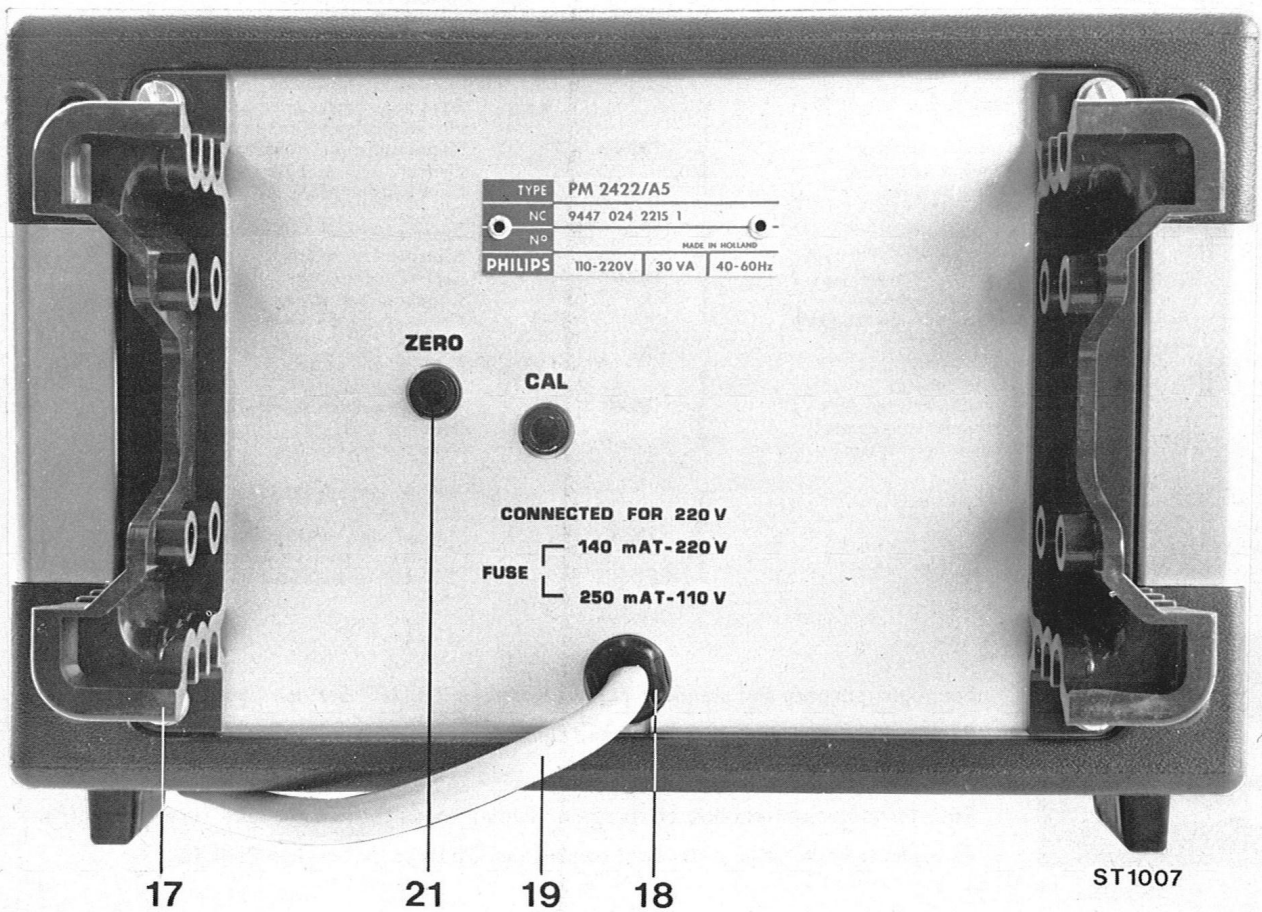

Fig. 31. Rear view with indication of item numbers

B. ELECTRICAL



















This parts list does not contain multi-purpose and standard parts. These components are indicated in the circuit diagram by means of identification marks. The specification can be derived from the survey below.

Diese Ersatzteilliste enthält keine Universal- und Standard-Teile. Diese sind im jeweiligen Prinzipschaltbild mit Kennzeichnungen versehen. Die Spezifikation kann aus nachstehender Übersicht abgeleitet werden.

In deze stuklijst zijn geen universele en standaardonderdelen opgenomen. Deze componenten zijn in het prinsipschema met een merkteken aangegeven. De specificatie van deze merktekens is hieronder vermeld.

La présente liste ne contient pas des pièces universelles et standard. Celles-ci ont été repérées dans le schéma de principe. Leurs spécifications sont indiquées ci-dessous.

Esta lista de componentes no comprende componentes universales ni standard. Estos componentes están provistos en el esquema de principio de una marca. El significado de estas marcas se indica a continuación.

	Carbon resistor E24 series Kohleschichtwiderstand, Reihe E24 Koolweerstand E24 reeks Résistance au carbone, série E24 Resistencia de carbón, serie E24	} 0,125 W 5%		Carbon resistor E12 series Kohleschichtwiderstand, Reihe E12 Koolweerstand E12 reeks Résistance au carbone, série E12 Resistencia de carbón, serie E12	} 1 W ≤ 2,2 MΩ, 5% > 2,2 MΩ, 10%
	Carbon resistor E12 series Kohleschichtwiderstand, Reihe E12 Koolweerstand E12 reeks Résistance au carbone, série E12 Resistencia de carbón, serie E12		} 0,25 W ≤ 1 MΩ, 5% > 1 MΩ, 10%		
	Carbon resistor E24 series Kohleschichtwiderstand, Reihe E24 Koolweerstand E24 reeks Résistance au carbone, série E24 Resistencia de carbón, serie E24	} 0,5 W ≤ 5 MΩ, 1% > 5 MΩ ≤ 10 MΩ, 2% > 10 MΩ, 5%			Wire-wound resistor Drahtwiderstand Draadgewonden weerstand Résistance bobinée Resistencia bobinada
	Carbon resistor E12 series Kohleschichtwiderstand, Reihe E12 Koolweerstand E12 reeks Résistance au carbone, série E12 Resistencia de carbón, serie E12		} 0,5 W ≤ 1,5 MΩ, 5% > 1,5 MΩ, 10%		Wire-wound resistor Drahtwiderstand Draadgewonden weerstand Résistance bobinée Resistencia bobinada
	Wire-wound resistor Drahtwiderstand Draadgewonden weerstand Résistance bobinée Resistencia bobinada	} 10 W 5%			
	Tubular ceramic capacitor Rohrkondensator Keramische kondensator, buistype Condensateur céramique tubulaire Condensador cerámico tubular		} 500 V		Polyester capacitor Polyesterkondensator Polyesterkondensator Condensateur au polyester Condensador polyester
	Tubular ceramic capacitor Rohrkondensator Keramische kondensator, buistype Condensateur céramique tubulaire Condensador cerámico tubular	} 700 V			Flat-foil polyester capacitor Miniatur-Polyesterkondensator (flach) Platte miniatuur polyesterkondensator Condensateur au polyester, type plat Condensador polyester, tipo de placas planas
	Ceramic capacitor, "pin-up" Keramikkondensator "Pin-up" (Perltyp) Keramische kondensator "Pin-up" type Condensateur céramique, type perle Condensador cerámico, versión "colgable"		} 500 V		Paper capacitor Papierkondensator Papierkondensator Condensateur au papier Condensador de papel
	"Microplate" ceramic capacitor Miniatur-Scheibenkondensator "Microplate" keramische kondensator Condensateur céramique "microplate" Condensador cerámico "microplaca"	} 30 V			Wire-wound trimmer Drahttrimmer Draadgewonden trimmer Trimmer à fil Trimmer bobinado
	Mica capacitor Glimmerkondensator Micakondensator Condensateur au mica Condensador de mica		} 500 V		Tubular ceramic trimmer Rohrtrimmer Buisvormige keramische trimmer Trimmer céramique tubulaire Trimmer cerámico tubular



For multi-purpose and standard parts, please see PHILIPS' Service Catalogue.

Für die Universal- und Standard-Teile siehe den PHILIPS Service-Katalog.

Voor universele en standaardonderdelen raadplege men de PHILIPS Service Catalogus.

Pour les pièces universelles et standard veuillez consulter le Catalogue Service PHILIPS.

Para piezas universales y standard consulte el Catálogo de Servicio PHILIPS.

Resistors

No.	Ordering number	Value	%	Series	Description
R102	5322 101 14045	330 kΩ	20	0.5 W	Potentiometer
R103	5322 101 14045	330 kΩ	20	0.5 W	Potentiometer
R104	5322 116 54379	9.76 MΩ	1		Metal film
R105	5322 116 51019	90 kΩ	0.1	MR54C	Metal film
R106	5322 116 50943	9 kΩ	0.1	MR34C	Metal film
R107	5322 116 54381	996 Ω	0.1	MR34C	Metal film
R108	5322 112 20076	68 Ω	5	4.2 W	Wire-wound
R110	5322 116 50525	14.7 kΩ	1	MR25	Metal film
R112	5322 112 20052	8.2 Ω	10	4.2 W	Wire-wound
R113	5322 112 20052	8.2 Ω	10	4.2 W	Wire-wound
R114	5322 112 20052	8.2 Ω	10	4.2 W	Wire-wound
R115	5322 112 20052	8.2 Ω	10	4.2 W	Wire-wound
R116	5322 115 80099	0.1+0.9 Ω	0.25		Wire-wound
R117	5322 113 24095	4.5 Ω	0.25	0.6 W	Wire-wound
R118	5322 113 24095	4.5 Ω	0.25	0.6 W	Wire-wound
R119	5322 113 24096	90 Ω	0.25	0.6 W	Wire-wound
R120	5322 113 24097	900 Ω	0.25	0.6 W	Wire-wound
R201	5322 116 51059	34.8 kΩ	1	MR25	Metal film
R204	5322 116 50451	21.5 kΩ	1	MR25	Metal film
R205	5322 116 50524	3.01 kΩ	1	MR25	Metal film
R206	5322 116 54156	154 kΩ	1	MR30	Metal film
R207	5322 116 54156	154 kΩ	1	MR30	Metal film
R208	5322 101 20277	2.2 kΩ	20	0.1 W	Potentiometer
R212	5322 100 10152	22 kΩ	20	0.5 W	Potentiometer
R214	5322 116 54078	10.5 kΩ	0.5	MR24C	Metal film
R215	5322 116 54141	1.15 kΩ	0.5	MR24C	Metal film
R216	5322 100 10054	47 Ω	20	0.5 W	Potentiometer
R301	5322 116 50631	4.53 kΩ	1	MR25	Metal film
R302	5322 100 10124	220 Ω	20	0.5 W	Potentiometer
R304	5322 100 10154	4.7 MΩ	20	0.1 W	Potentiometer
R308	5322 116 50915	9.53 kΩ	1	MR25	Metal film
R309	5322 116 50915	9.53 kΩ	1	MR25	Metal film
R401	5322 116 50747	1 kΩ	0.5	MR24C	Metal film
R402	5322 116 54595	5.11 kΩ	1	MR25	Metal film
R403	5322 101 14046	680 Ω	20	0.5 W	Potentiometer
R404	5322 116 50855	4.02 kΩ	1	MR25	Metal film
R503	5322 116 50406	86.6 kΩ	1	MR25	Metal film
R504	5322 116 50406	86.6 kΩ	1	MR25	Metal film
R505	5322 100 10124	220 Ω	20	0.5 W	Potentiometer
R507	5322 116 50559	27.4 kΩ	1	MR25	Metal film
R515	4822 100 10052	100 kΩ	1	0.1 W	Potentiometer
R601	5322 116 50765	909 Ω	1	MR25	Metal film
R602	5322 116 50509	4.87 kΩ	1	MR25	Metal film
R603	5322 100 10137	470 Ω	20	0.5 W	Potentiometer
R604	5322 103 10047	100 Ω	20	0.5 W	Potentiometer

No.	Ordering number	Value	%	Series	Description
R605	5322 116 50379	1.43 k Ω	1	MR24	Metal film
R607	5322 116 54058	2.49 k Ω	0.1	MR24C	Metal film
R608	5322 116 54051	1.05 k Ω	0.1	MR24C	Metal film
R609	5322 116 54058	2.49 k Ω	0.1	MR24C	Metal film
R610	5322 116 50749	1.4 k Ω	1	MR25	Metal film
R611	5322 100 10125	10 k Ω	20	0.5 W	Potentiometer
R612	5322 100 10114	4.7 k Ω	20	0.5 W	Potentiometer
R733	5322 116 50557	46.4 k Ω	1	MR25	Metal film
R734	5322 116 50557	46.4 k Ω	1	MR25	Metal film
R735	5322 116 50557	46.4 k Ω	1	MR25	Metal film
R736	5322 116 50557	46.4 k Ω	1	MR25	Metal film
R803	5322 116 50458	7.87 k Ω	1	MR25	Metal film
R804	5322 116 50945	7.15 k Ω	1	MR25	Metal film
R805	5322 116 54239	5.36 Ω	1	MR25	Metal film
R806	5322 116 54221	3.65 k Ω	1	MR25	Metal film
R807	5322 116 50524	3.01 k Ω	1	MR25	Metal film
R808	5322 116 50524	3.01 k Ω	1	MR25	Metal film
R809	5322 116 50522	13 k Ω	1	MR25	Metal film
R810	5322 116 50524	3.01 k Ω	1	MR25	Metal film
R811	5322 116 50578	78.7 Ω	1	MR25	Metal film
R813	5322 116 50976	56.2 k Ω	1	MR25	Metal film
R814	5322 116 50576	95.3 k Ω	1	MR25	Metal film
R815	5322 116 54136	681 Ω	1	MR25	Metal film

Capacitors

No.	Ordering number	Value	%	V	Description
C1	5322 121 40149	100 nF	10	630	Polyester
C2	5322 122 14003	1 nF	20	400	Ceramic
C101	5322 125 64003	9 pF		500	Trimmer
C102	5322 122 34032	39 pF	2	500	Ceramic
C103	4822 122 31205	47 pF	2	500	Ceramic
C104	5322 120 64117	2.4 nF	1	500	Polyester
C105	5322 121 50287	22 nF	1	63	Polyester
C106	4822 120 11069	35 pF	5	500	Ceramic
C201	4822 122 31174	2.7 nF	10	500	Ceramic
C202	4822 122 31174	2.7 nF	10	500	Ceramic
C203	4822 121 40045	22 nF		250	Polyester
C205	4822 122 30128	4.7 nF	10	100	Ceramic
C206	4822 122 31167	2.2 nF	10	100	Ceramic
C207	4822 122 30043	10 nF	10	100	Ceramic
C208	4822 122 30043	10 nF	10	100	Ceramic
C209	4822 122 30008	47 pF	2	63	Ceramic
C301	4822 122 30008	47 pF	2	63	Ceramic
C302	4822 122 30002	150 pF	2	63	Ceramic
C303	4822 122 31049	6.2 pF		100	Ceramic
C304	4822 122 30043	10 nF	10	100	Ceramic
C305	4822 122 30043	10 nF	10	100	Ceramic
C306	4822 122 30004	5.6 pF		63	Ceramic

No.	Ordering number	Value	%	V	Description
C307	5322 121 40233	680 nF	10	100	Polyester
C308	5322 121 40283	3.3 μ F	10	100	Polyester
C309	5322 121 40197	1 μ F	10	100	Polyester
C501	5322 121 40175	470 nF	10	100	Polyester
C502	5322 121 40323	100 nF	10	100	Polyester
C503	4822 121 40231	150 nF	10	100	Polyester
C504	5322 122 30103	22 nF		40	Ceramic
C505	4822 122 30021	100 pF	2	63	Ceramic
C506	4822 122 31175	1 nF	10	100	Ceramic
C701	5322 121 40323	100 nF	10	100	Polyester
C702	4822 121 40057	68 nF	10	250	Polyester
C703	4822 121 40057	68 nF	10	250	Polyester
C704	4822 121 40057	68 nF	10	250	Polyester
C705	4822 121 40057	68 nF	10	250	Polyester
C709	5322 121 40323	100 nF	10	100	Polyester
C710	5322 121 40323	100 nF	10	100	Polyester
C711	5322 121 40323	100 nF	10	100	Polyester
C801	4822 124 20399	220 μ F		40	Electrolytic
C802	4822 122 30021	100 pF	2	63	Ceramic
C803	4822 124 20362	22 μ F		25	Electrolytic
C804	4822 124 20399	220 μ F		40	Electrolytic
C805	4822 122 31177	470 pF	10	100	Ceramic
C806	4822 124 20362	22 μ F		25	Electrolytic
C807	4822 124 20436	6.4 μ F		300	Electrolytic
C808	4822 124 20362	22 μ F		25	Electrolytic

Miscellaneous

Item	Ordering number	Description
T1	5322 146 24053	Mains transformer
VL1	5322 253 30008	Mains fuse 110 mA (220 V mains)
	4822 253 30013	Mains fuse 250 mA (110 V mains)
VL101	4822 253 20007	Fuse 125 mA
VL102	5322 252 60019	Spark gap
VL103	5322 253 20028	Fuse 6.3 A
L1	5322 158 14036	HF Choke
L2		
LA701	5322 134 24013	Neon lamp GL14
LA702	5322 134 20057	Neon lamp
B703	5322 131 94002	Indicator ZM1005
B704		
B705		
	PM 9260	Set measuring leads

Transistors

Type	Ordering number	Qty.	Item
BC107	5322 130 40357	3	TS201, TS202, TS801
BFQ12	5322 130 44248	1	TS203,
BFW11	5322 130 40408	1	TS204
BCY56	5322 130 40325	2	TS401, TS502
BFQ15	5322 130 44409	1	TS501
BRY39	5322 130 40482	1	TS503
BC178	5322 130 40355	3	TS601, TS703, TS704
BF338	5322 130 44108	3	TS701, TS803, TS804
BSV68	5322 130 44058	4	TS707, TS708, TS709, TS710
2N2905A	5322 130 40468	1	TS802

Diodes

Type	Ordering number	Qty.	Item
BYX72-500	5322 130 34388	4	GR101, GR102, GR103, GR104
BZX70-C12	5322 130 30753	2	GR105, GR106
BZX79-C8V2	5322 130 34119	1	GR201
BZX79-C5V6	5322 130 30759	2	GR202/203
BAV10	5322 130 30594	2	GR301, GR302
BZX79-B5V1	5322 130 34223	1	GR402
BAW62	5322 130 30613	15	GR501, GR503, GR701, GR702, GR703, GR704, GR705, GR706, GR707, GR708, GR709, GR710, GR712, GR714, GR716
BZX79-C5V1	5322 130 30767	2	GR502, GR601
BZV11	5322 130 34294	1	GR602
BZX79-C68	5322 130 34234	1	GR711
BAX17	5322 130 30605	3	GR713, GR715, GR718
BZX75-C2V1	5322 130 34049	1	GR717
BZX79-B5V6	5322 130 34173	1	GR801
BY164	5322 130 30414	1	GR802
BZX79-C6V2	5322 130 30766	1	GR202, GR203, GR803
BZX79-C5V6	5322 130 30759	2	GR804, GR805
BZX61-C56	5322 130 30566	2	GR806, GR807
BY179	5322 130 30521	1	GR808
BZX75-C3V6	5322 130 30765	1	GR809

Integrated circuits

Type	Ordering number	Qty.	Item
ULN2139D	5322 209 84333	1	IC201
U9T7101392	5322 209 84691	1	IC301
TBA221B	5322 209 84486	3	IC401, IC501, IC601
FEY101B-S1	5322 209 84496	1	IC502
FEJ271B	5322 209 84336	1	IC701
SN74141AN	5322 209 84138	1	IC702
TBA281	5322 209 80245	2	IC801, IC802

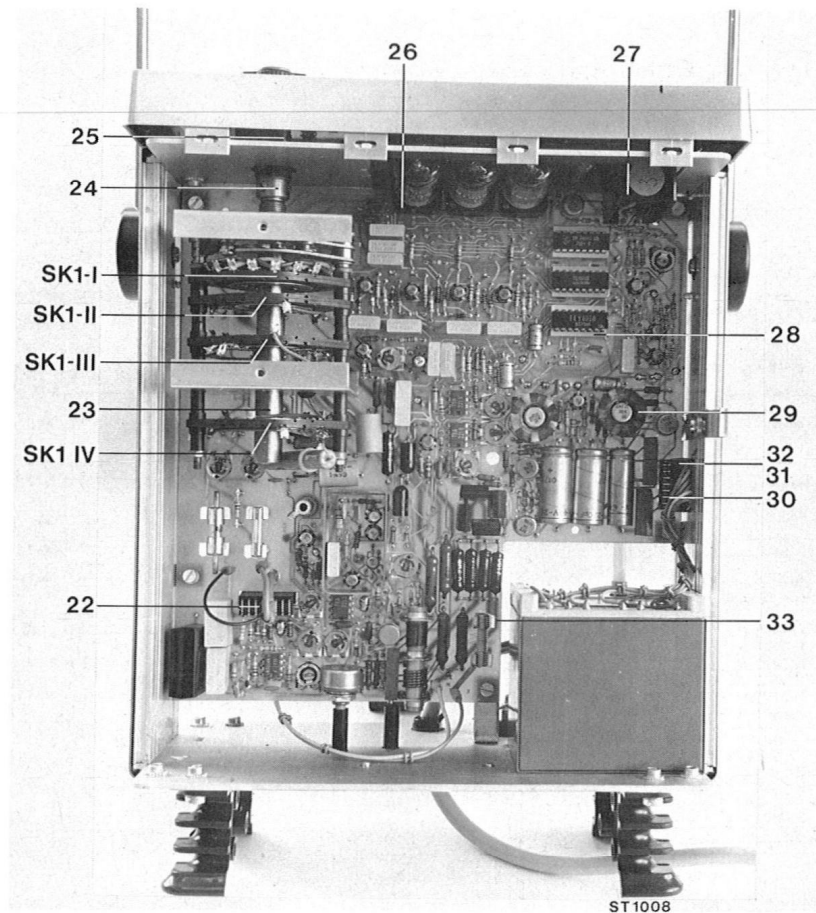

Fig. 32. Top view

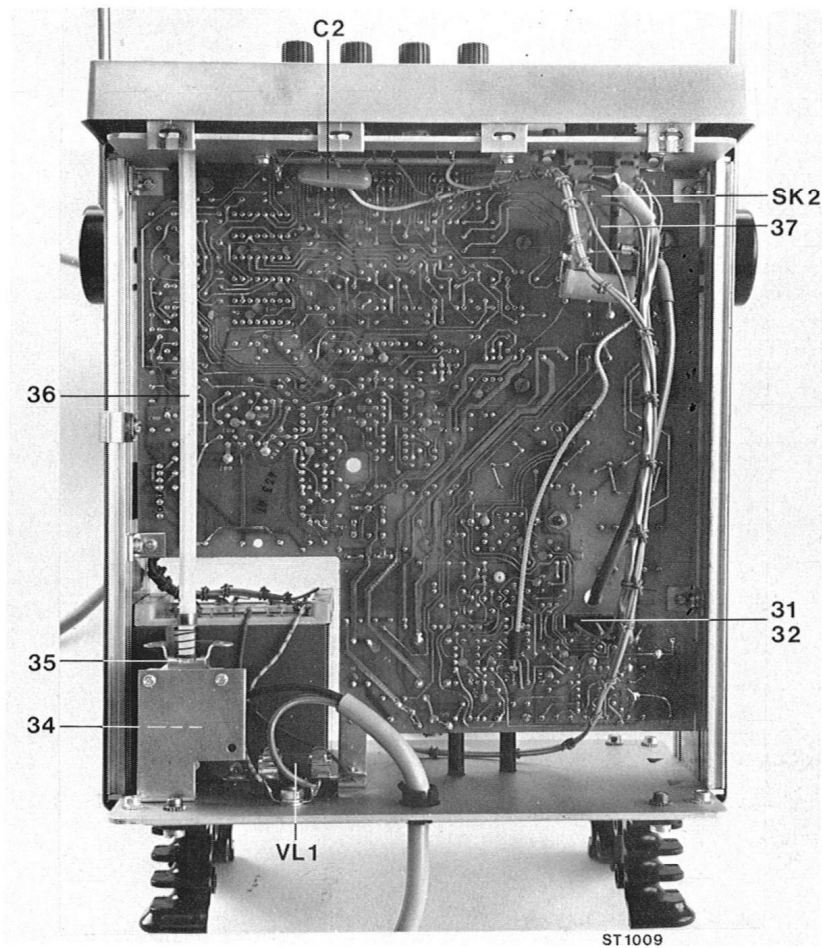

Fig. 33. Bottom view

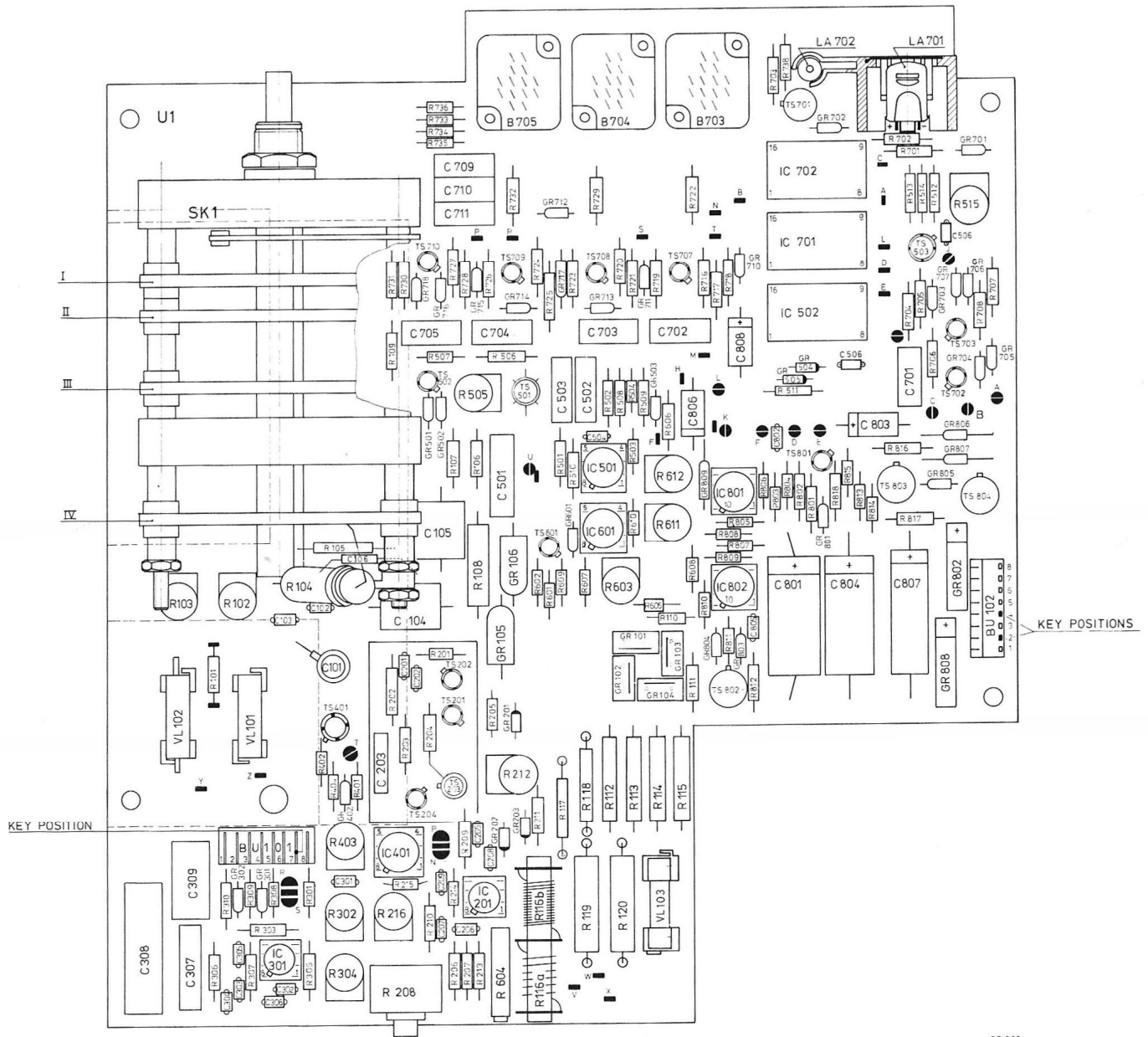

Fig. 34. Printed wiring board U 1

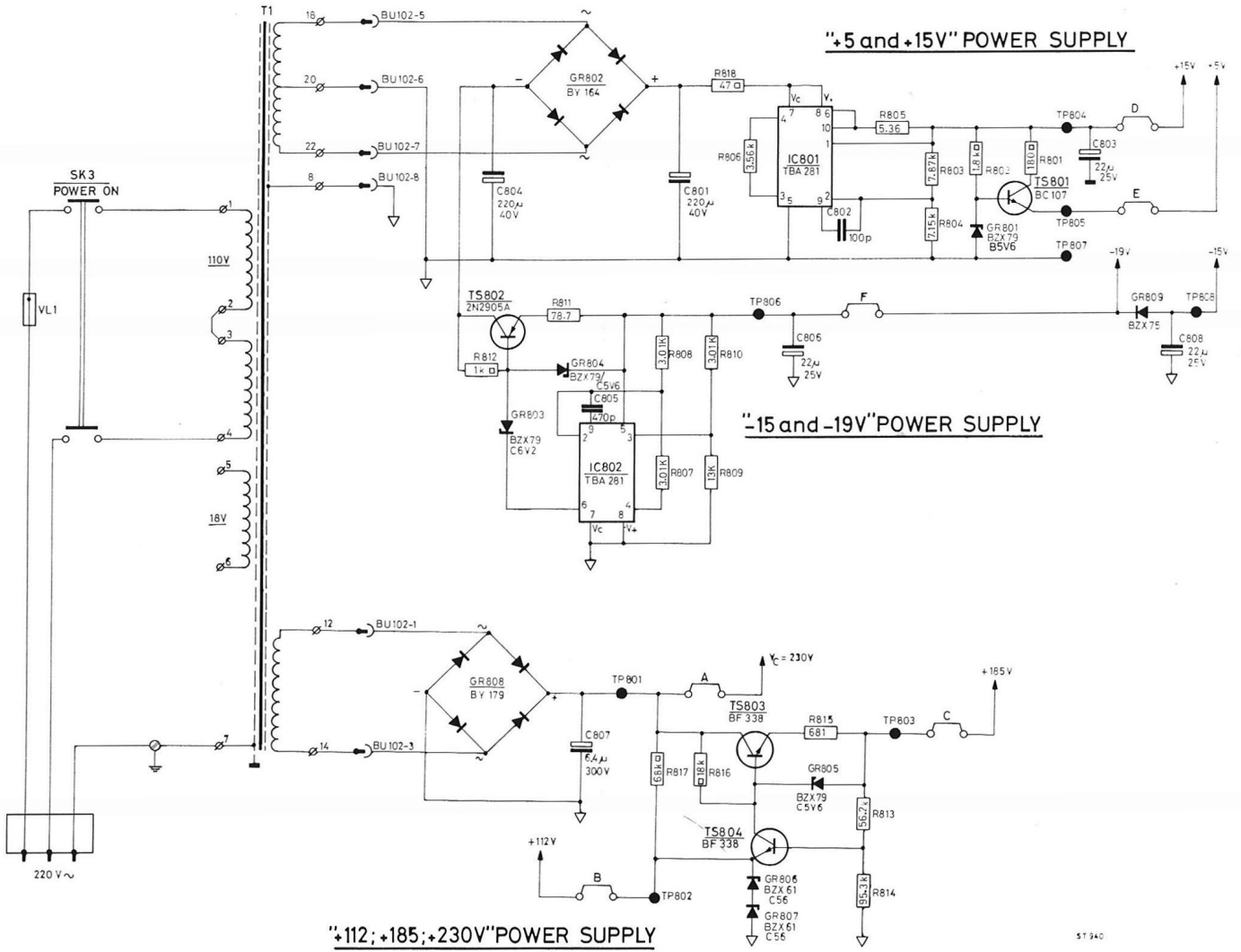

Fig. 35. Circuit diagram supply section PM 2422 A

TABLE 1

Test point	Function	Range	Measuring results				
			DC voltage	AC voltage	Resistors	Currents	
101	V-R input	200 mV	value of	value of	-	-	
		2 V	d. c. voltage	a. c. voltage	-	-	
		20 V	supplied to	supplied to	-	-	
		200 V	input	input	-	-	
		1000 V			-	-	
		200 Ω	-	-	199.9 mV	} at end of range	-
		2 k Ω	-	-	1.999 V		-
		20 k Ω	-	-	199.9 mV		-
		200 k Ω	-	-	1.999 V		-
		2 M Ω	-	-	199.9 mV		-
		20 M Ω	-	-	1.999 V		-
		102	V-R input after fuse VL101	200 mV	value of	value of	-
2 V	d. c. voltage			a. c. voltage	-	-	
20 V	supplied to			supplied to	-	-	
200 V	input			input	-	-	
1000 V					-	-	
200 Ω	-			-	199.9 mV	} at end of range	-
2 k Ω	-			-	1.999 V		-
20 k Ω	-			-	199.9 mV		-
200 k Ω	-			-	1.999 V		-
2 M Ω	-			-	199.9 mV		-
20 M Ω	-			-	1.999 V		-
103	I Input			200 μ A	-	-	-
		2 mA	-	-	-		
		20 mA	-	-	-		
		200 mA	-	-	-		
		2 A	-	-	-		
104	I Input after fuse VL103	200 μ A	-	-	-	0.2 V a. c. or d. c. + voltage loss across wiring at end-of-range values	
		2 mA	-	-	-		
		20 mA	-	-	-		
		200 mA	-	-	-		
		2 A	-	-	-		
105	"0" Input		0 V	0 V	0 V	0 V	
107	Voltage across shunts	200 μ A	-	-	-	0.2 V a. c. or d. c. at end-of-range values	
		2 mA	-	-	-		
		20 mA	-	-	-		
		200 mA	-	-	-		
		2 A	-	-	-		
201	Input 1x/10x amplifier	200 mV	199.9 mV	199.9 mV _{r.m.s.}	-	} at end of range	-
		2 V	1.999 V	1.999 V _{r.m.s.}	-		-
		20 V	199.9 mV	199.9 mV _{r.m.s.}	-		-
		200 V	1.999 V	1.999 V _{r.m.s.}	-		-
		1000 V	1 V	0.6 V _{r.m.s.}	-		-
		200 Ω	-	-	1.999 mV		-
		2 k Ω	-	-	1.999 V		-
		20 k Ω	-	-	1.999 mV		-
		200 k Ω	-	-	1.999 V		-
		2 M Ω	-	-	199.9 mV		-
		20 M Ω	-	-	1.999 V		-

Test point	Function	Range	Measuring results			
			DC voltage	AC voltage	Resistors	Currents
		200 μ A	-	-	-	
		2 mA	-	-	-	199.9 mV a.c. or
		20 mA	-	-	-	d.c. at end of
		200 mA	-	-	-	range
		2 A	-	-	-	
202	Checking the functioning of the protection: - Supply + and -20 V d.c. to TP201 - The voltage at TP202 should be $+8\text{ V} \pm 2\text{ V}$, respectively $-8\text{ V} \pm 2\text{ V}$					
203	Drain TS203A and TS203B	2 V DC (TP201 = 0 V)	$+8.2\text{ V} \pm 5\%$			
204	Source TS203A	}	at 0 V at the input (TP201) voltage at TP204 and TP205			
205	Source TS203B					
206	Feedback 1x/10x amplifier In position: gain 10x, the voltage at TP206 is $\frac{1}{10}$ of the voltage at TP207 In position: gain 1x, the voltage at TP206 is equal to the voltage at TP207					
207	Output 1x/10x amplifier		2 V d.c. at d.c. and resistance measurements 2 V a.c. at a.c. measurements 0 V at $V_i = 0$ (TP201 = 0 V)			} at end-of-range
208	1x/10x switch In position: gain 10x, TP208 = 0 V In position: gain 1x, the voltage at TP208 is equal to the voltage at TP207					
401	Output IC401	200 Ω 2 k Ω 20 k Ω 200 k Ω 2 M Ω 20 M Ω input shorted	- - - - - -	- - - - - -	+1.20 V +3.00 V +1.20 V +3.00 V +1.20 V +3.00 V	} at end-of-range -range
402	- Input IC401	200 Ω 2 k Ω 20 k Ω 200 k Ω 2 M Ω 20 M Ω	- - - - - -	- - - - - -	+199.9 mV +1.999 V 199.9 mV 1.999 V 199.9 mV 1.999 V	- - - - - -
403	Base TS401		-10 V in all ranges			
404	Collector TS401		same values as for TP402			

By means of the jumpers of Fig. 27 circuits may be interrupted for separate testing purposes. Interruption is done by removing the solder from the spot by means of a vacuum soldering iron.

A short survey of the jumpers follows:

Jumper		Function
A	Supply +230 V	Measuring of unloaded supply voltages
B	Supply +112 V	
C	Supply +185 V	
D	Supply + 15 V	
E	Supply + 5 V	
F	Supply - 19 V	
		It is recommended to interrupt always jumper A in order to prevent damaging of the circuits.
J	Overrange out	No detection of over-range indication. Maximum reading of 2046.
K	Comparator out	No special function
L	Chopped output of ADC	
N	Input from current source	Separation of the current source for Ω measurements and d.c. amplifier
P	Feed-back of 1x/10x amplifier	Measuring open loop gain of IC 201
R	A.C. feed-back IC 301	AC behaviour of the a.c. - to d.c. converter
S	D.C. feed-back IC 301	DC behaviour of the a.c. - to d.c. converter
T	Output current source	Functioning of the current source
U	Input ADC	Separation of analogue part and digital part

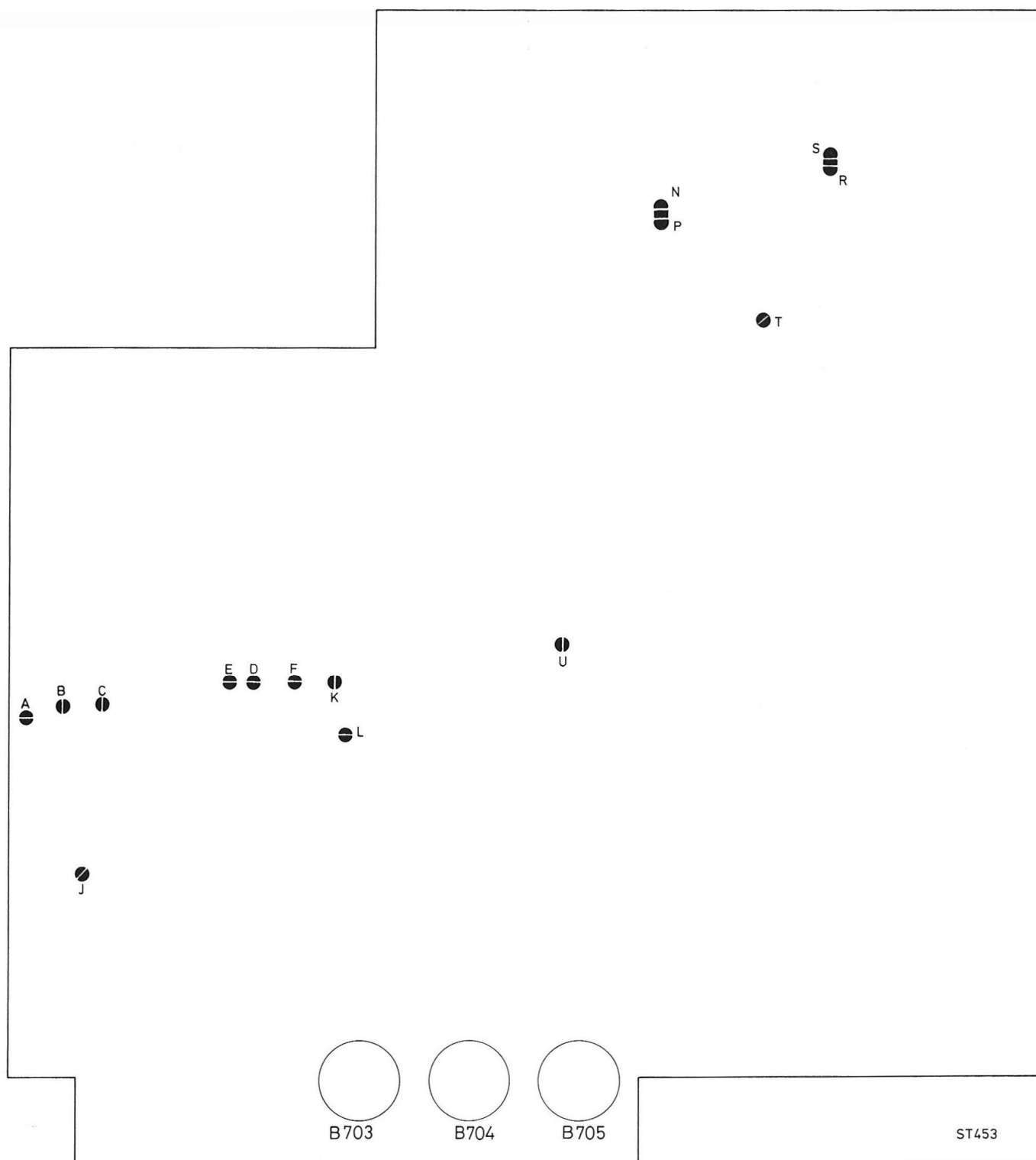

Fig. 27. Location of jumpers on the printed wiring board

X. CHECKING AND ADJUSTING SURVEY

The next table gives a survey of the adjustments and checking procedure of multimeter PM 2422A. For a complete adjustment adhere to the sequence of chapter XI.

Control element	Fig. 29	Checking or adjusting point	According to chapter XI sub-point
	-	<u>Supply voltages</u> +230 V, +185 V, +112 V, +15 V +5 V, -15 V and -19 V	A. 2.
R515		<u>Clock oscillator frequency</u>	B
		<u>ADC</u>	
R505		Zero setting comparator	C. 1.
R612		Zero setting ADC	C. 2.
R603	}	End-of-range calibration ADC (+)	C. 3.
R604			
R611			
		<u>Direct voltage ranges</u>	
R208		Zero setting	
R212		Offset DC amplifier	D. 1.
R216		Gain 10x	D. 2.
-	-	Linearity	D. 3.
R102		Attenuator (20 V and 200 V range)	D. 4.
		<u>Alternating voltage ranges</u>	
R302		End-of-range calibration } AC-to-DC Linearity } converter	E. 1.
R304			
C209		Frequency response 1x/10x amplifier	E. 2.
-	-	Linearity	E. 3.
C101		Frequency independent attenuator	E. 4.
C106		Frequency response	E. 5.
		<u>Resistance ranges</u>	
R403		Adjustment current source	F. 1.
R103		Calibration 2 M Ω and 20 M Ω ranges	F. 2.
-	-	<u>Direct current ranges</u>	G

Required test equipment

To calibrate this measuring instrument only reference voltages and measuring equipment with the required accuracy should be applied. The test equipment and standards required for checking, adjusting or calibration are listed in the next table.

Test	Required performance	Recommended equipment
DC Calibration	Accuracy : at least $\pm 0.04\%$ Range : 10 mV ... 1000 V	DC standard e.g. PM 2480
AC Calibration	Accuracy : at least $\pm 0.08\%$ Voltage : 10 mV - 110 V Frequency: 30 Hz ... 25 kHz	AC standard e.g. HP745A
	<u>Resistance accuracy</u>	
Resistance calibration	50 Ω	A series of standard resistors (e.g. metal film) or Guildline type 9330
	190 Ω	
	200 Ω	
	600 Ω	
	1 k Ω	
	1.4 k Ω	
	1.9 k Ω	
	19 k Ω	
	190 k Ω	
	1.9 M Ω	
19 M Ω	at least 0.1 %	
Supply voltages		Multimeter e.g. PM 2421
Pulse form		Oscilloscope e.g. PM 3231
Clock frequency		Counter e.g. PM 6630

XI. CHECKING AND ADJUSTING

The tolerances stated in this chapter correspond to the factory data, which only apply to a newly re-adjusted instrument. Such data may differ from these given in chapter II, TECHNICAL DATA. Values without tolerances represent the properties of an average instrument and serve merely for reference.

A survey of the adjustments and adjusting elements is given in chapter X.

Perform calibration after a warming-up time of approximately 30 minutes.

Any adjustment, maintenance, and repair of an instrument which is opened whilst connected to the mains should be avoided as far as possible and, if inevitable, shall be only carried out by skilled personnel familiar with the risk of shock involved.

A. SUPPLY

1. Current consumption

The current consumption amounts to

- for 110 V mains : 250 mA max.
- for 220 V mains : 125 mA max.

2. Supply voltages

Check the supply voltage in accordance with the next table at nominal mains voltage

Supply	Value	Measuring point
+230 V	+230 V \pm 15 V	TP801 (+) and terminal 0
+185 V	+185 V \pm 10 V	TP803 (+) and terminal 0
+112 V	+112 V \pm 8 V	TP802 (+) and terminal 0
+ 15 V	+ 15 V \pm 0.9 V	TP804 (+) and terminal 0
+ 5 V	+ 5 V \pm 0.3 V	TP805 (+) and terminal 0
- 15 V	- 15 V \pm 1.4 V	TP808 (-) and terminal 0
- 19 V	- 19 V \pm 1.2 V	TP806 (-) and terminal 0

B. CLOCK OSCILLATOR

- Connect an oscilloscope to test point L (SCAN)
- Check the pulse form (Fig. 28).

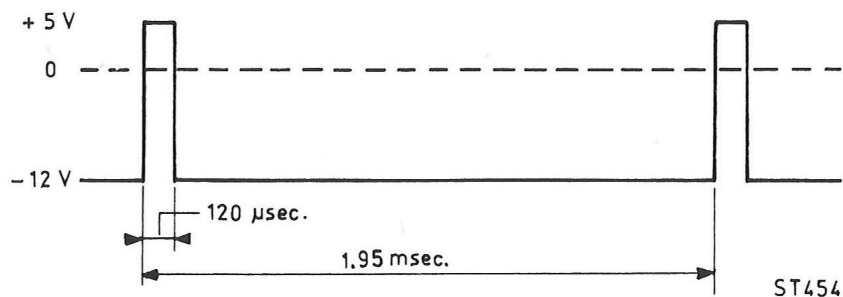

Fig. 28. Clock pulse

- Connect a counter (e.g. PM 6630) to test point L
- Adjust the frequency to 512 Hz ± 1 % with potentiometer R515 (the clock frequency will then be approximately 8.2 kHz).

C. ADC

1. Zero setting comparator

- Pull-out connector BU101 (by this the digital section is separated from the analog section)
- Connect pin U (input ADC) and jumper L (= TP505) with the zero level (e.g. terminal "0")
- Connect an oscilloscope to TP504 (output comparator).

Oscilloscope settings: time base 0.5 msec/div.

amplitude 5 V/div.

Adjust potentiometer R505 as well as possible for zero level on the oscilloscope (within 1 div.)

- Remove the made connections

2. End-of-range calibration ADC

- Supply +1990 mV to test point U
- Adjust the reading to 1990 with potentiometer R604 (potentiometer CAL available at the rear)
- Supply -1990 mV to test point U.
- Adjust the reading to -1990 with potentiometer R611

3. Zero setting ADC

- Supply alternately + and -10 mV from a DC standard to test point U
 - Adjust the reading to +010 and -010 with potentiometer R612.
- Repeat C2 and C3, after which BU101 should be connected.

D. CALIBRATING AND CHECKING THE DIRECT VOLTAGE RANGES

1. Calibration

- Interconnect terminals V-R (BU3) and 0 (BU2)
 - Set range selector SK1 to 200 mV
 - Depress button DC-R (SK2/1)
 - Set potentiometer R208 (potentiometer ZERO available at the rear) to its mid-position
 - Adjust the reading to 00.0 ± 3 digits with potentiometer R212.
- With potentiometer R208 (ZERO) the reading can be adjusted to 000.
- Set range selector SK1 to 2 V
 - The reading should be .000. If not, the adjustment of the ADC is incorrect. Repeat sub-point C.
 - Supply +1990 mV
 - Adjust the reading to 1990 ± 0 digits with potentiometer R604 (potentiometer CAL available at the rear)
 - Supply -1990 mV
 - The reading should be -1990 ± 1 digit (if necessary, readjust with potentiometer R611).

2. Adjustment 1x/10x amplifier

- Set range selector SK1 to 200 mV
- Perform zero setting with potentiometer ZERO (R208)
- Supply +199.0 mV to inputs V-R (BU3) and 0 (BU2)
- Adjust the reading to 199.0 ± 0 digits with potentiometer R216
- Supply -199.0 mV
- The reading should be -199.0 ± 1 digit.

3. Checking the linearity

- Set range selector SK1 to position 200 mV
- Check the linearity of the instrument in accordance with the next table for positive as well as for negative voltages.

Supply to BU2-BU3	Reading
5 mV	05.0 ± 2 digits
10 mV	10.0 ± 2 digits
20 mV	20.0 ± 2 digits
40 mV	40.0 ± 2 digits
60 mV	60.0 ± 2 digits
80 mV	80.0 ± 2 digits
100 mV	100.0 ± 2 digits
120 mV	120.0 ± 2 digits
140 mV	140.0 ± 2 digits
160 mV	160.0 ± 2 digits
180 mV	180.0 ± 2 digits
199 mV	199.0 ± 2 digits

4. DC attenuator

Adjust or check the attenuator in accordance with the next table

Range selector to position	Supply to BU2-BU3	Reading	Adjust with
20 V	+ 19.9 V	19.90 ± 0 digits	R102
200 V	+199 V	199.0 ± 1 digit	-
1000 V	+990 V	990 ± 1 digit	-

E. CALIBRATING AND CHECKING THE ALTERNATING VOLTAGE RANGES

1. AC-to-DC converter

- Depress button AC (SK2/2).
- Adjust the converter in accordance with the next table

Range selector to position	Supply to BU2-BU3	Reading	Adjust with
200 mV	short-circuited	00.0 \pm 5 digits	-
2 V	19 mV, 1 kHz	.019	R304
2 V	1900 mV, 1 kHz	1.900 \pm 1 digit	R302
2 V	short-circuited	.000 \pm 1 digit	
2 V	19 mV, 1 kHz	.019	R304
2 V	1900 mV, 1 kHz	1.900 \pm 1 digit	R302

2. Frequency response AC-to-DC converter

- Adjust the converter in accordance with the next table

Range selector to position	Supply to BU2-BU3	Reading
200 mV	190 mV, 20 kHz	190.0 \pm 5 digits
2 V	1.9 V, 20 kHz	1.900 \pm 5 digits

If the reading in range 200 mV is too high and in range 2 V correct or too low, the value of capacitor C209 should be made higher.

If the reading in range 2 V is too high and in range 200 mV correct or too low, the value of capacitor C209 should be made smaller.

3. Checking the linearity

- Set range selector SK1 to position 200 mV

- Check the linearity of the instrument at a frequency of 1 kHz in accordance with the next table

Supply to BU2-BU3	Reading	Tolerance
5 mV	05.0	} \pm 2 digits
20 mV	20.0	
40 mV	40.0	
60 mV	60.0	
80 mV	80.0	
100 mV	100.0	
120 mV	120.0	
140 mV	140.0	
160 mV	160.0	
180 mV	180.0	
190 mV	190.0	

4. Frequency independent attenuator

Adjust and check the attenuator in accordance with the next table

Range selector to position	Supply to BU2-BU3	Reading	Adjust with
200 mV	190 mV, 15 kHz	"X" (note this value)	-
20 V	19 V, 15 kHz	noted value "X"	C101
20 V	19 V, 150 Hz	19.00 \pm 4 digits	-
20 V	19 V, 1.5 kHz	19.00 \pm 4 digits	

5. Checking the frequency response

Check the frequency response in accordance with the next table

Range selector to position	Supply to BU2-BU3	Frequency	Reading	Tolerance
20 V	19 V	30 Hz	19.00	± 6 digits
		100 Hz	19.00	± 4 digits
		300 Hz	19.00	± 4 digits
		1 kHz	19.00	± 4 digits
		3 kHz	19.00	± 4 digits
		10 kHz	19.00	± 4 digits
		20 kHz	19.00	± 6 digits
		25 kHz	19.00	± 8 digits
200 V	109 V	30 Hz	109.0	± 6 digits
		100 Hz	109.0	± 4 digits
		300 Hz	109.0	± 4 digits
		1 kHz	109.0	± 4 digits
		3 kHz	109.0	± 4 digits
		10 kHz	109.0	± 4 digits
		20 kHz	109.0	± 4 digits
		25 kHz	109.0	± 8 digits
600 V AC	600 V	1 kHz	600	± 4 digits

If the deviation (downwards) is too large, add C106 parallel to C104 (ceramic capacitor 39 pF).

F. RESISTANCE RANGES

1. Adjustment

- Depress button DC/R (SK2/1)
- Set range selector SK1 to 200 k Ω
- The reading should be 0 (overload)
- Interconnect terminals V-R (BU3) and 0 (BU2)
- The reading should be 00.0 ± 1 digit
- Connect a resistor of 190 k Ω to terminals V-R (BU3) and 0 (BU2)
- Adjust the reading to 190.0 ± 1 digit with potentiometer R403
- Set range selector SK1 to position 2 M Ω
- Interconnect terminals V-R (BU3) and 0 (BU2)
- The reading should be .000 ± 1 digit (to be corrected with potentiometer ZERO at the rear)
- Connect a resistor of 1.9 M Ω to terminals V-R and 0
- Adjust the reading to 1.900 ± 1 digit with potentiometer R103
- Check the other ranges in accordance with the next table

Range selector to position	Connect to BU2-BU3	Reading	Tolerance
200 Ω	190 Ω	190.0	± 4 digits
20 k Ω	19 k Ω	19.00	± 4 digits
20 M Ω	19 M Ω	19.00	± 4 digits

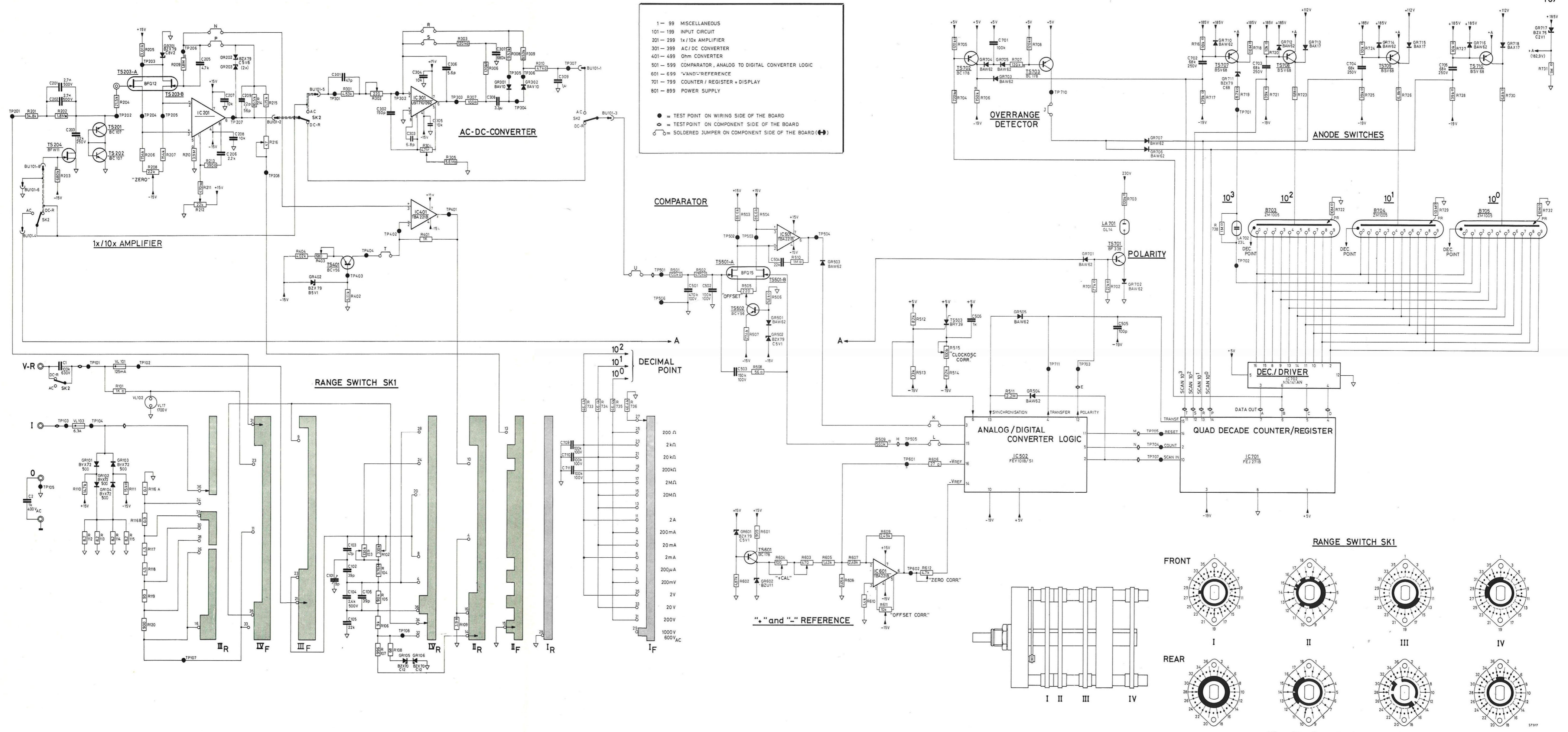

Fig. 36. Circuit diagram analog and digital section PM 2422 A

2. Linearity

- Set range selector SK1 to position 2 kΩ
- Check the linearity in accordance with the table below

Connect to	Reading	Tolerance
BU2-BU3		
50 Ω	.050	± 2 digits
200 Ω	.200	± 3 digits
600 Ω	.600	± 3 digits
1000 Ω	1.000	± 3 digits
1400 Ω	1.400	± 3 digits
1900 Ω	1.600	± 4 digits

G. CHECKING THE DIRECT CURRENT RANGES

- Depress button DC/R (SK2/1).
- Check the direct current ranges in accordance with the next table

Range selector to position	Supply to BU4 a current of	Reading	Tolerance
200 μA	190 μA	190.0	± 6 digits
2 mA	1.9 mA	1.900	
20 mA	19 mA	19.00	
200 mA	190 mA	190.0	
2 A	1.9 A	1900	

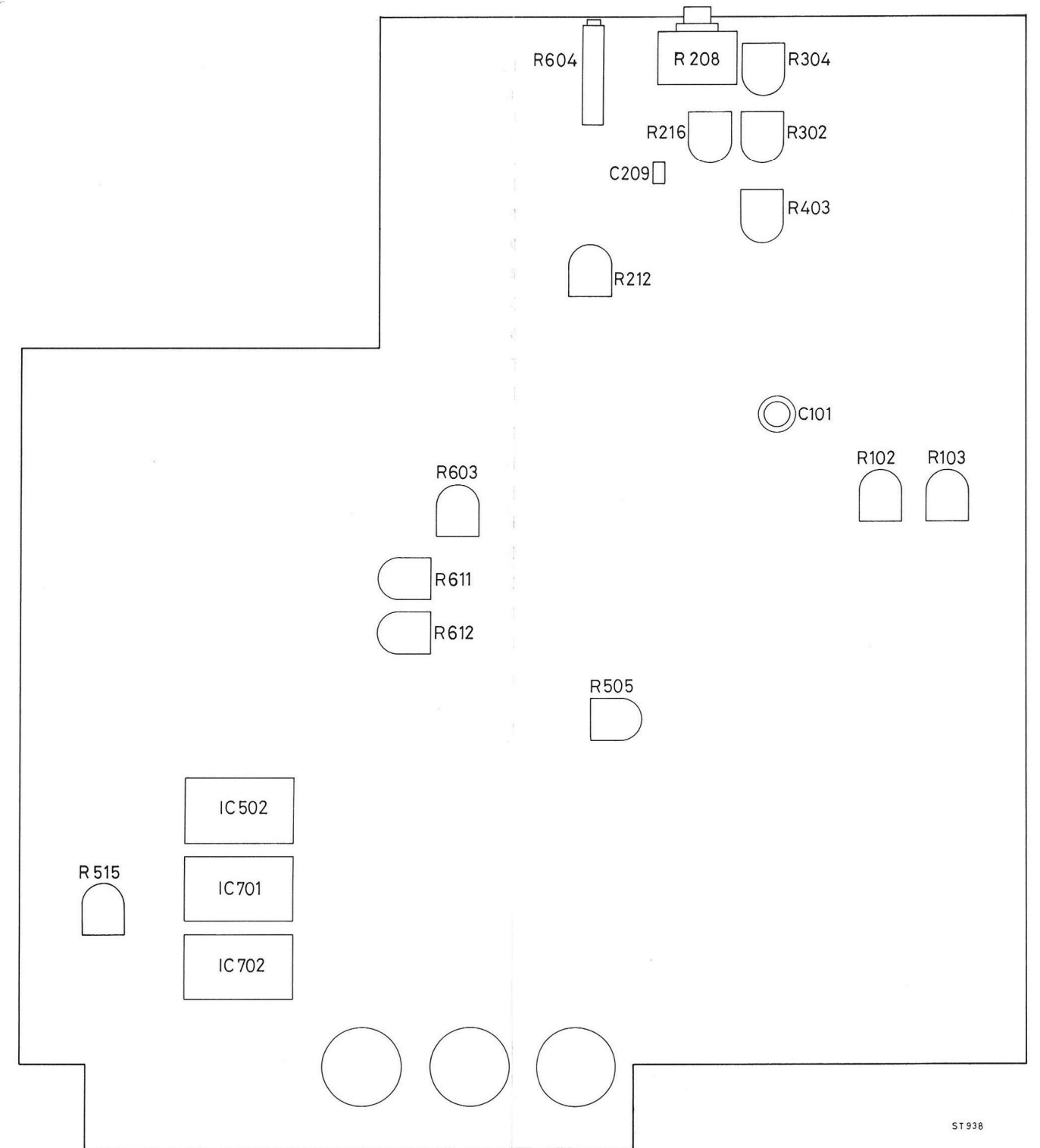

Fig. 29. Location of adjusting elements